

CONFIDENTIAL INFORMATION: DO NOT DISTRIBUTE
 THE INFORMATION CONTAINED IN THIS DRAWING IS THE SOLE PROPERTY OF THE UNIVERSITY OF MAINE. ANY REPRODUCTION IN PART OR AS A WHOLE WITHOUT THE WRITTEN PERMISSION OF THE UNIVERSITY OF MAINE IS PROHIBITED.

NOTES:

- 3/16" WELD ALL AROUND.
 - PAINT UMAINE BLUE; PANTONE: PMS 289. (ALL FABRICATED STEEL COMPONENTS SHALL BE PAINTED, D-SHAFTS, GUIDE WHEELS, CASTOR WHEELS, AND HARDWARE SHALL NOT BE PAINTED.)
 - ONE ASSEMBLY REQUIRED.
 - TOTAL WEIGHT OF CREEL ASSEMBLY=9890 LB.
 - FABRICATOR SHALL ASSEMBLE AND TEST SLIDING COMPONENT OF CREEL ASSEMBLY PRIOR TO COMPLETION AND DELIVERY.
 - FABRICATOR SHALL ALLOW REPRESENTATIVE OF UMAINE TO COME AND INSPECT FABRICATION PRIOR TO COMPLETION AND DELIVERY.
 - FABRICATION TOLERANCES UNLESS NOTED ARE +/- 1/16"
- MACHINING:
 .X +/-0.060"
 .XX +/-0.010"
 .XXX +/-0.005"
 ANGLE +/-1/2"

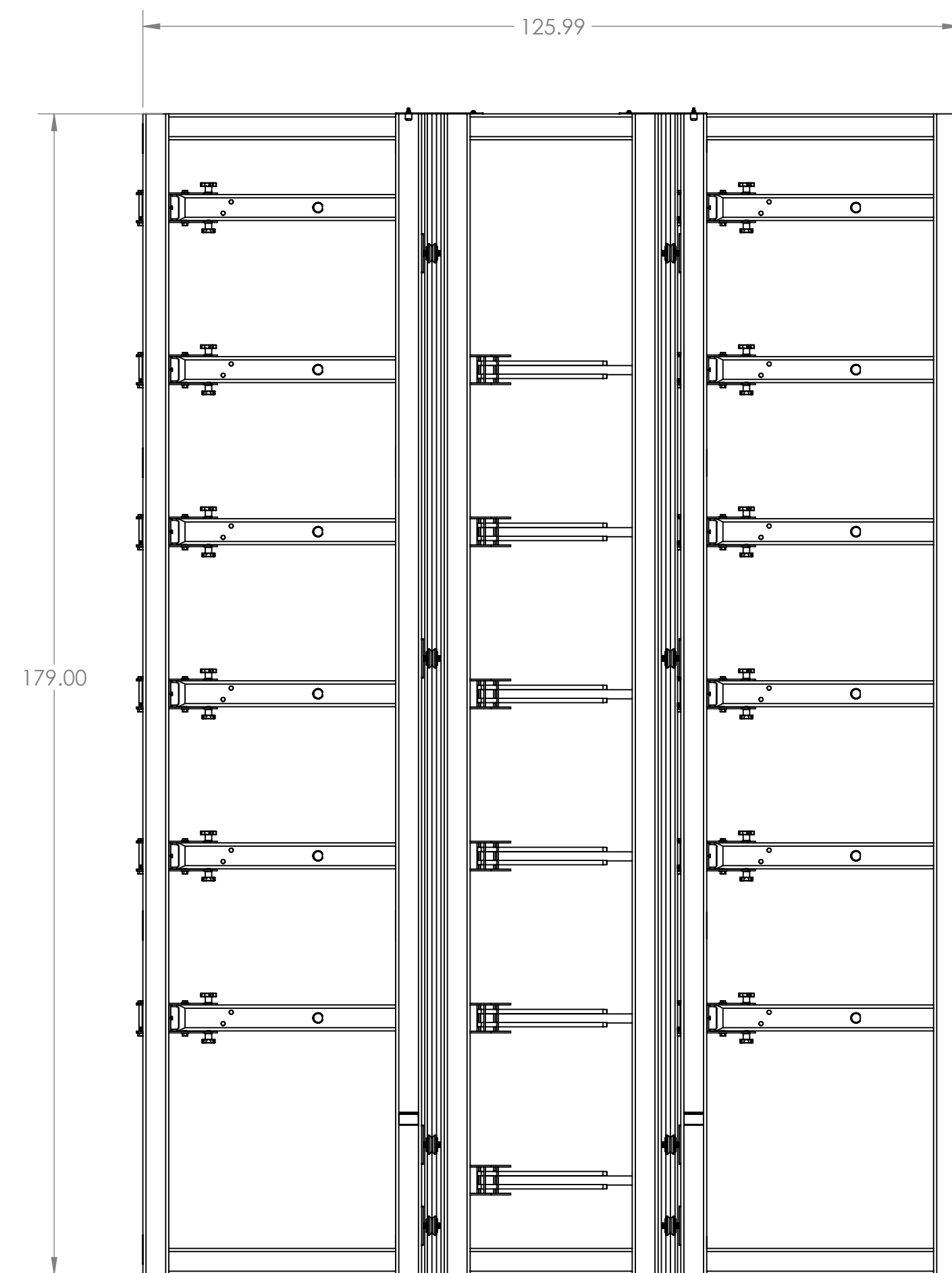

PLAN
SCALE 1:20

CREEL GUIDES FOR DETAILS SEE SHEET 005

GUIDE STOP FOR DETAILS SEE SHEET 012

LEFT SIDE CREEL FOR DETAILS SEE SHEET 006

CENTER CREEL FOR DETAILS SEE SHEET 004

RIGHT SIDE CREEL FOR DETAILS SEE SHEET 002

CREEL OUTER ARM ASSEMBLY FOR DETAILS SEE SHEET 009

CREEL INNER ARM ASSEMBLY FOR DETAILS SEE SHEET 010

CREEL ROLLER ASSEMBLY FOR DETAILS SEE SHEET 011

CREEL GUIDE WHEEL ASSEMBLY FOR DETAILS SEE SHEET 008

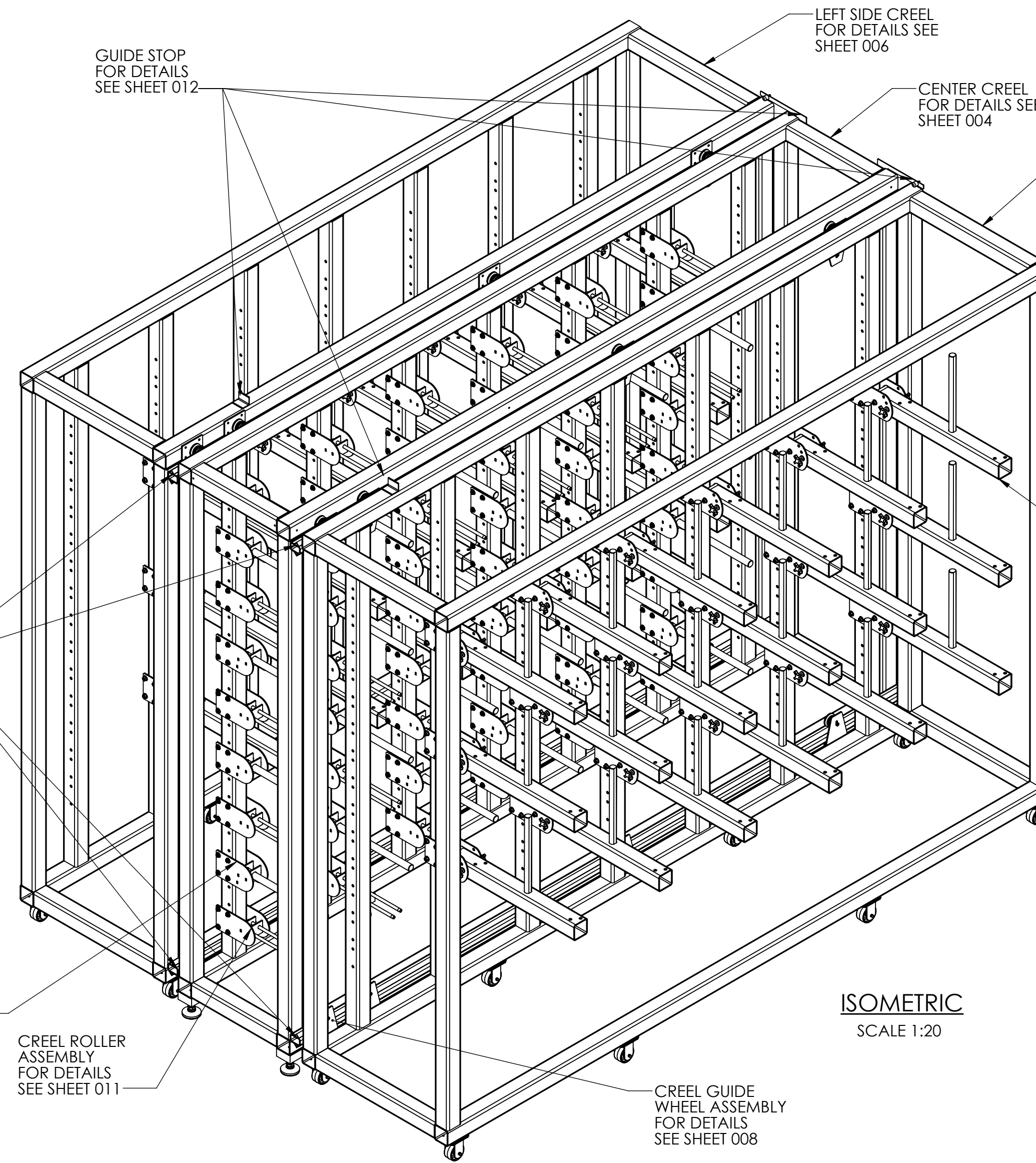

ISOMETRIC
SCALE 1:20

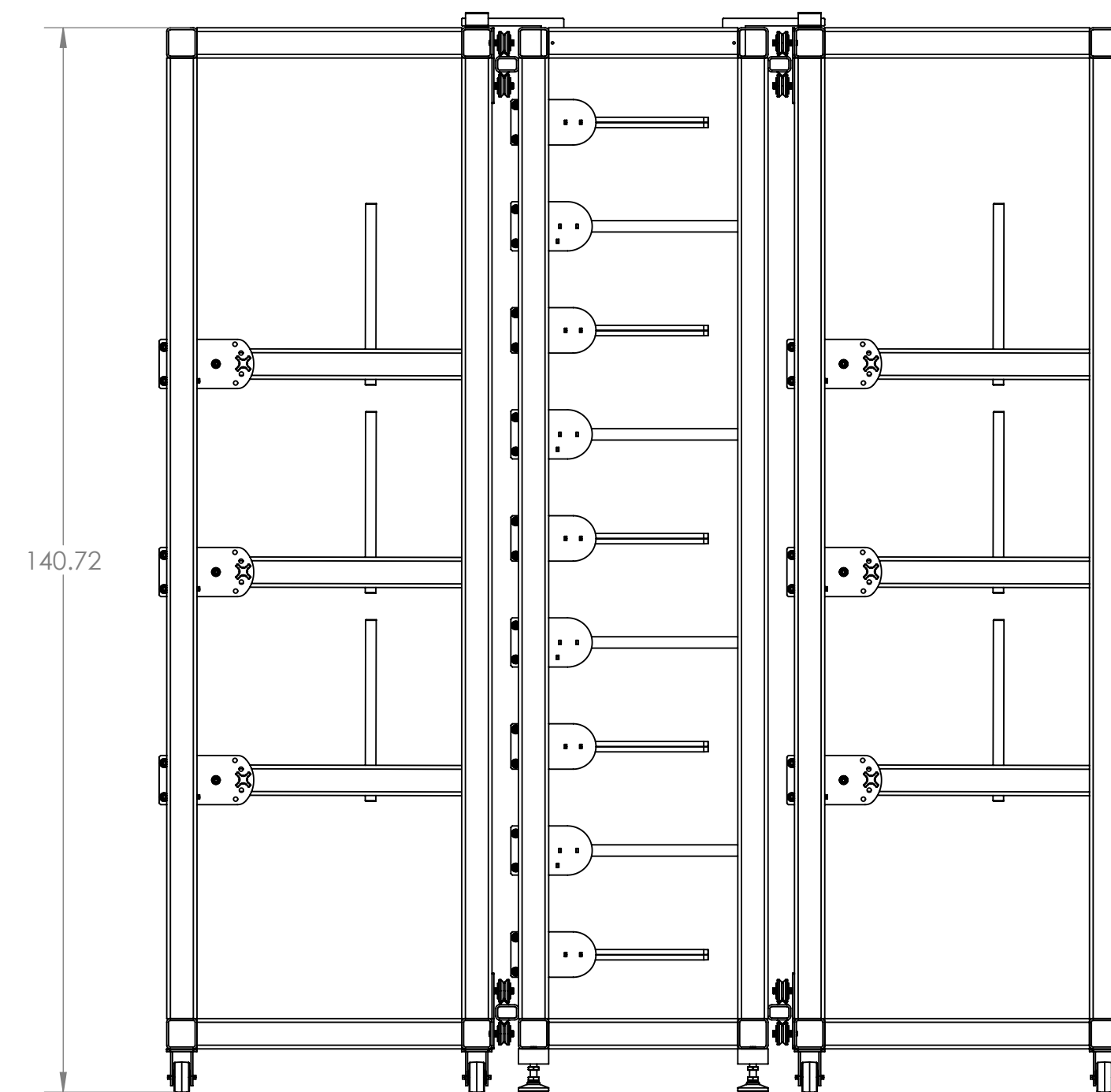

END VIEW
SCALE 1:20

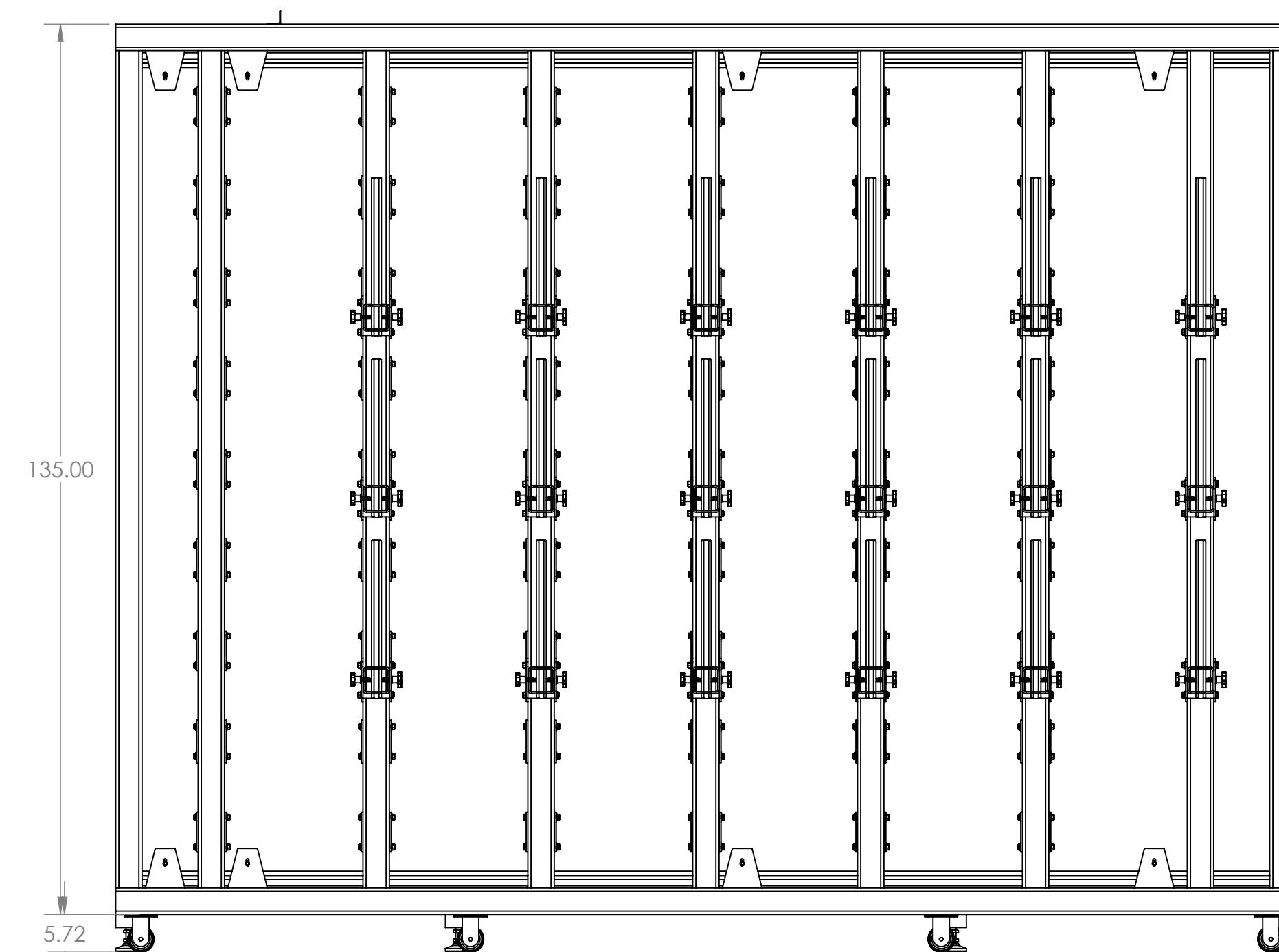

SIDE VIEW
SCALE 1:20

0	RELEASED FOR QUOTE	12/18/2025
		PJ
NO.	REVISIONS	DATE:
		APPROVED BY:
UNLESS OTHERWISE SPECIFIED: DIMENSIONS ARE IN FEET & INCHES		
DESIGNED	NP	09/01/2025
DRAWN	JF	10/31/2025
CHECKED	PJ	12/02/2025
APPROVED		

TITLE:
CFM GEN 3.0
CREEL ASSEMBLY

SCALE: AS NOTED

PROJ. NO.

SIZE	SHEET NO.	REV
D	001	0

CONFIDENTIAL INFORMATION: DO NOT DISTRIBUTE
 THE INFORMATION CONTAINED IN THIS DRAWING IS THE SOLE PROPERTY OF THE UNIVERSITY OF MAINE. ANY REPRODUCTION IN PART OR AS A WHOLE WITHOUT THE WRITTEN PERMISSION OF THE UNIVERSITY OF MAINE IS PROHIBITED.

BOM TABLE/ RIGHT SIDE CREEL				
ITEM NO.	PART NUMBER	DESCRIPTION	QTY.	LENGTH IN INCHES
1		HSS4X4X1/4	1	179
2		HSS4X4X1/4	4	35
3		HSS4X4X1/4	4	127
4		HSS4X4X1/4	7	127
5		HSS4X4X1/4	1	179
6		HSS4X4X1/4	1	179
7		HSS4X4X1/4	1	179
8	MCMASTER #2856T24	HIGH-CAPACITY SPARTAN CASTER WITH 5" X 4" MOUNTING PLATE	8	
9	07_WHEEL PLATE	1/8 STEEL PLATE	8	

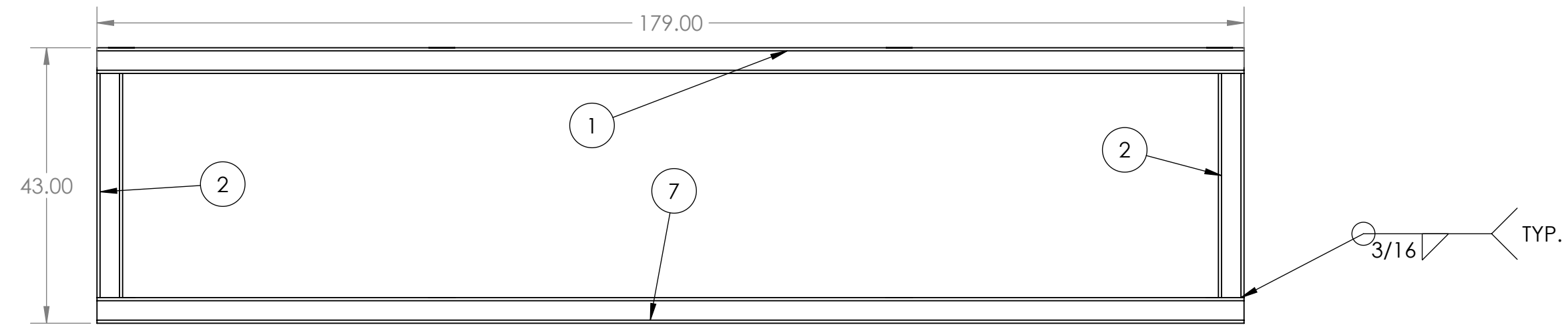

PLAN
SCALE 1:20

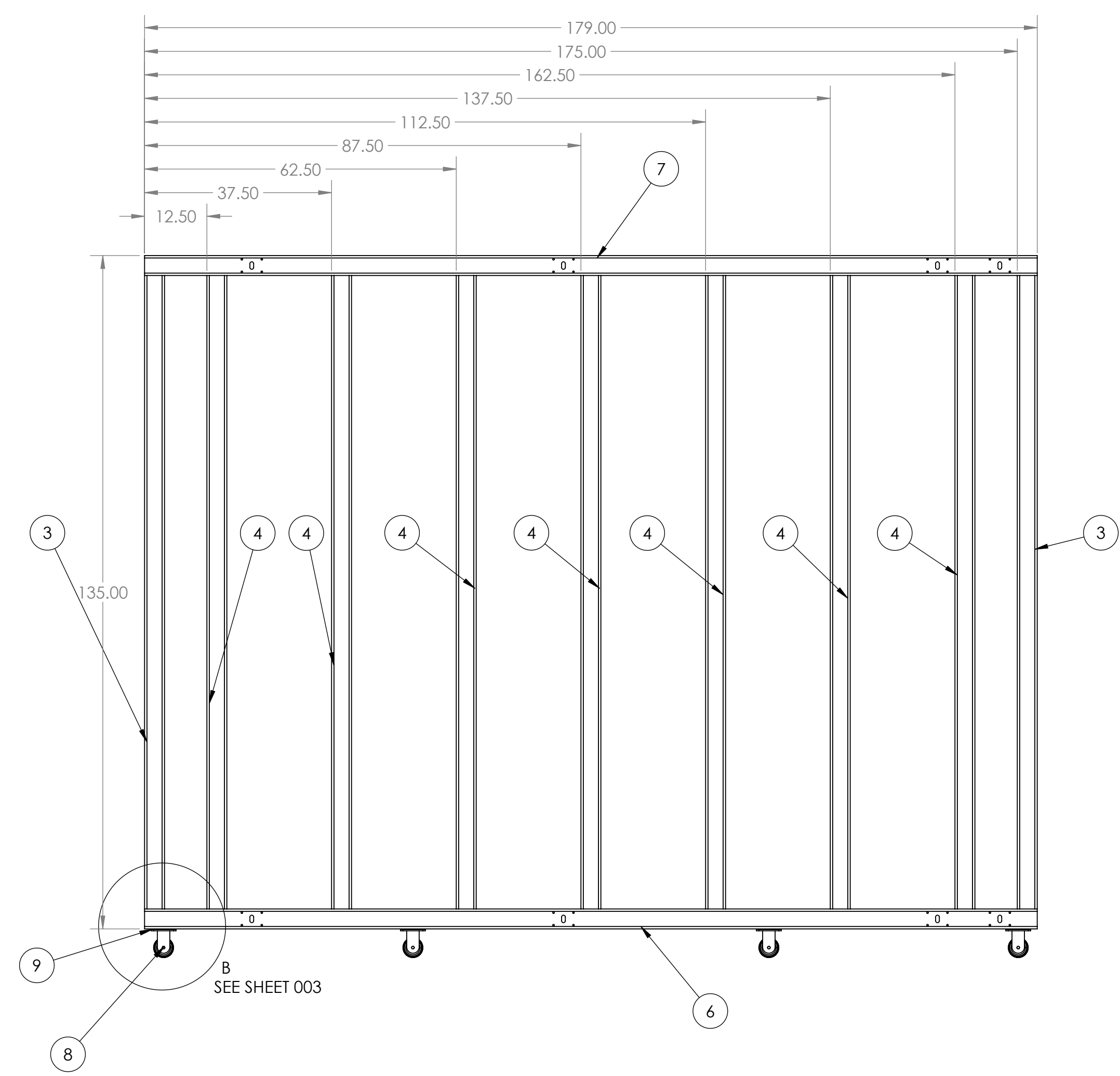

SIDE VIEW
SCALE 1:20

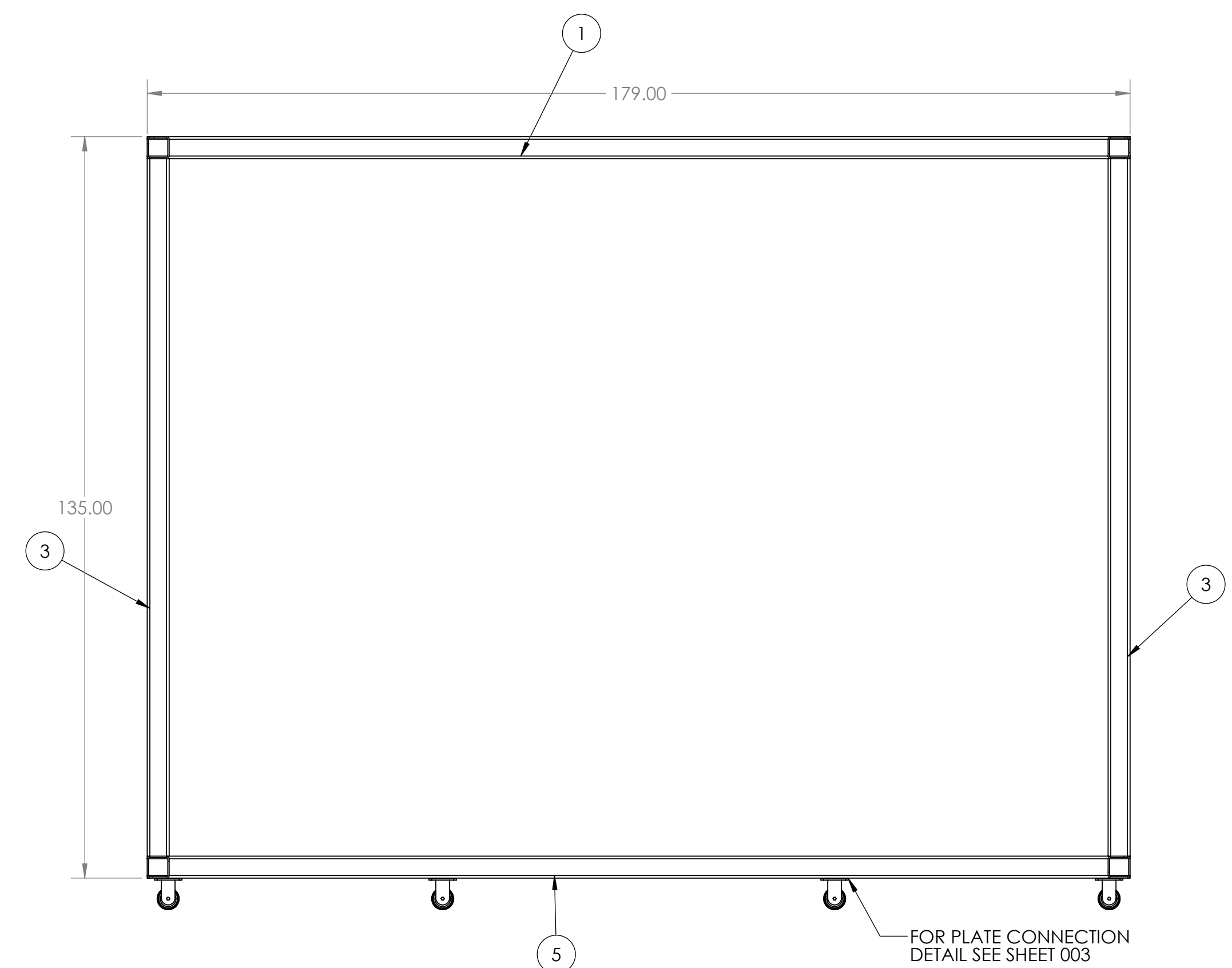

SECTION A-A
SCALE 1:20

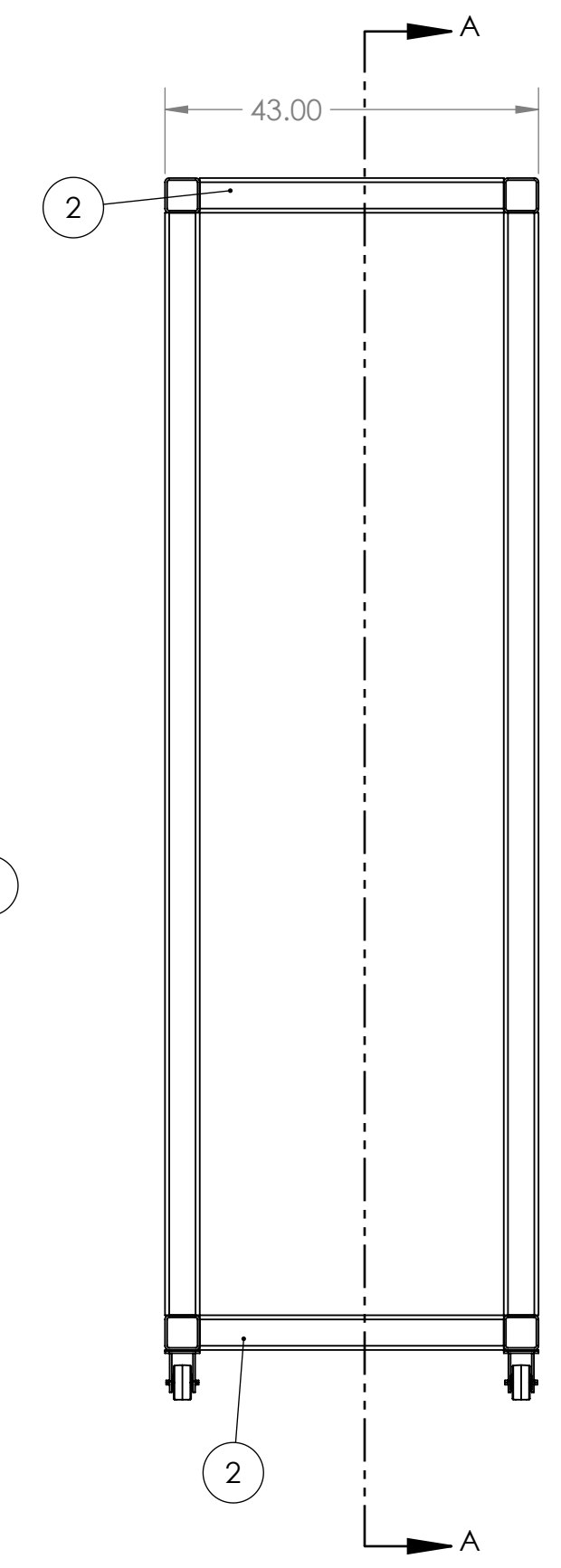

END VIEW
SCALE 1:20

NOTES:

NO.	REVISIONS	DATE	APPROVED BY:
0	RELEASED FOR QUOTE	12/18/2025	PJ

TITLE:
CFM GEN 3.0
RIGHT SIDE CREEL

SCALE: AS NOTED

PROJ. NO.

SIZE	SHEET NO.	REV
D	002	0

CONFIDENTIAL INFORMATION: DO NOT DISTRIBUTE
 THE INFORMATION CONTAINED IN THIS DRAWING IS THE SOLE PROPERTY OF THE UNIVERSITY OF MAINE. ANY REPRODUCTION IN PART OR AS A WHOLE WITHOUT THE WRITTEN PERMISSION OF THE UNIVERSITY OF MAINE IS PROHIBITED.

NOTES:
 HSS4x4x1/4 FOR ALL STEEL MEMBERS.

0	RELEASED FOR QUOTE	12/18/2025
		PJ
		DATE:
		APPROVED BY:
UNLESS OTHERWISE SPECIFIED: DIMENSIONS ARE IN FEET & INCHES		
DESIGNED	NP	09/01/2025
DRAWN	JF	10/31/2025
CHECKED	PJ	12/02/2025
APPROVED		

TITLE:
**CFM GEN 3.0
 RIGHT SIDE CREEL
 DETAILS I**

SCALE: AS NOTED

PROJ. NO.

SIZE	SHEET NO.	REV
D	003	0

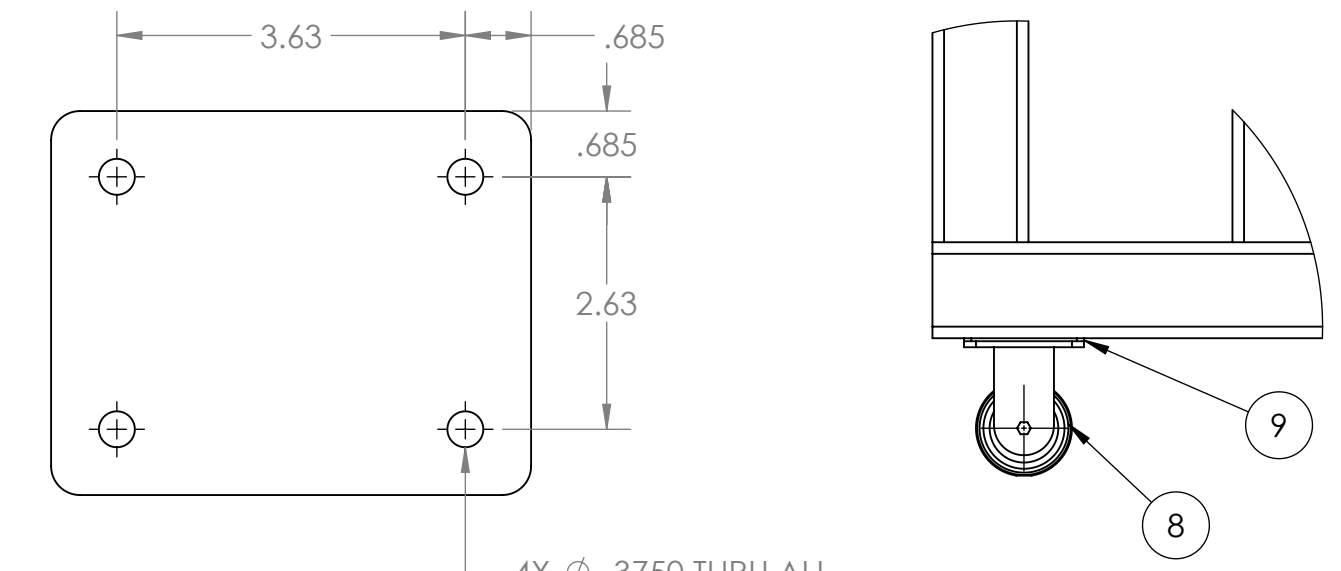

PLAN
SCALE 1:2

DETAIL B
SCALE 1:8

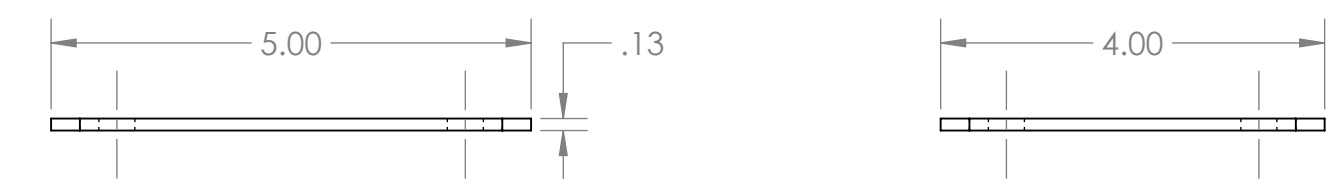

9 DETAIL
SCALE 1:2

SIDE VIEW
SCALE 1:2

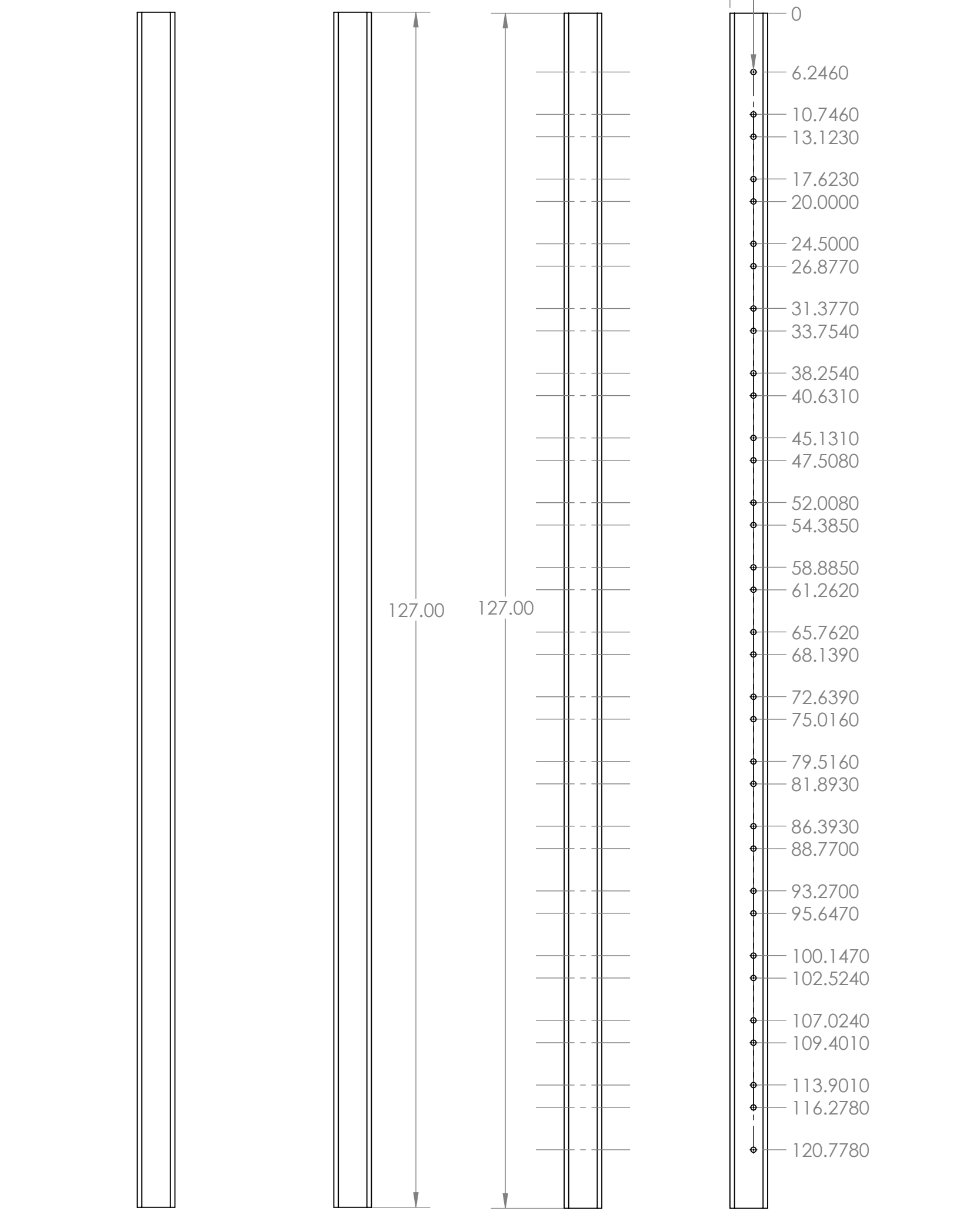

3 DETAIL
SCALE 1:12

SIDE VIEW
SCALE 1:12

4 DETAIL
SCALE 1:12

SIDE VIEW
SCALE 1:12

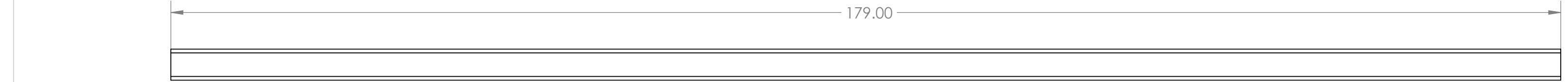

SIDE VIEW
SCALE 1:12

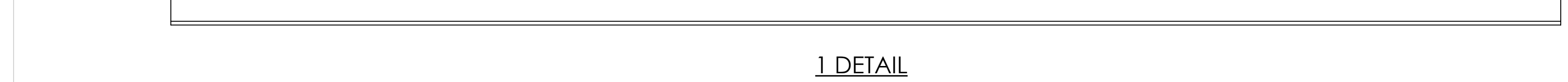

1 DETAIL
SCALE 1:12

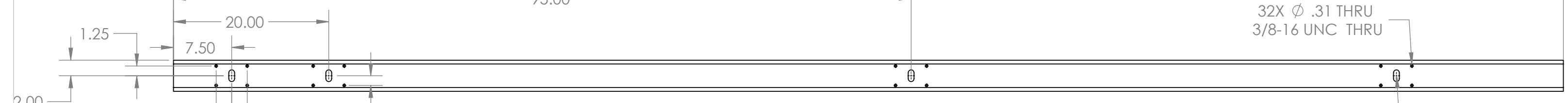

SIDE VIEW
SCALE 1:12



7 DETAIL
SCALE 1:12

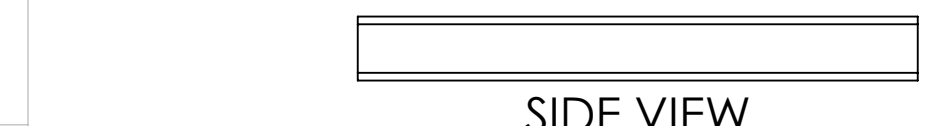

SIDE VIEW
SCALE 1:12



2 DETAIL
SCALE 1:12

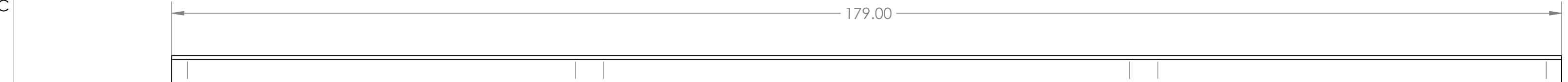

SIDE VIEW
SCALE 1:12

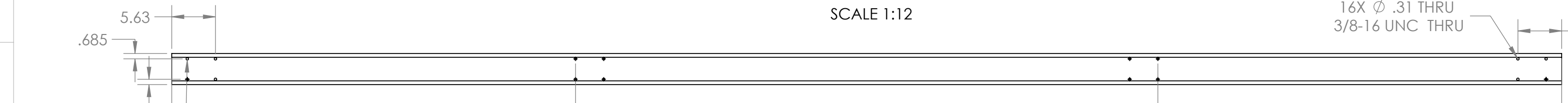

5 DETAIL
SCALE 1:12

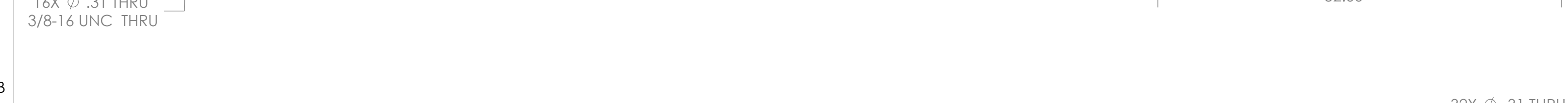

SIDE VIEW
SCALE 1:12

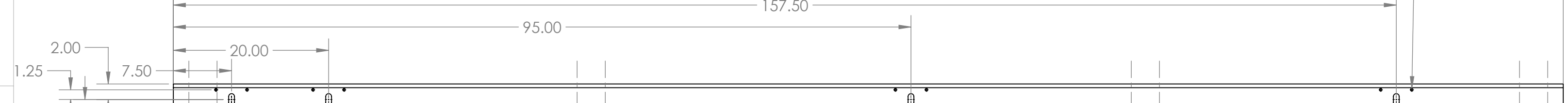

6 DETAIL
SCALE 1:12



SIDE VIEW
SCALE 1:12



SIDE VIEW
SCALE 1:12

FILENAME: C:\Users\peterlabern\OneDrive - University of Maine System (1)\Continuous Forming Machine - 10_Gen 3\02_Creel\Creeel Sliding (current)\Creel Drawings

CONFIDENTIAL INFORMATION: DO NOT DISTRIBUTE
 THE INFORMATION CONTAINED IN THIS DRAWING IS THE SOLE PROPERTY OF THE UNIVERSITY OF MAINE. ANY REPRODUCTION IN PART OR AS A WHOLE WITHOUT THE WRITTEN PERMISSION OF THE UNIVERSITY OF MAINE IS PROHIBITED.

NOTES:
 1. 3/16" WELD ALL AROUND.

BOM TABLE/ CENTER CREEL				
ITEM NO.	PART NUMBER	DESCRIPTION	QTY.	LENGTH IN INCHES
1		HSS4X4X1/4	1	179
2		HSS4X4X1/4	1	25
3		HSS4X4X1/4	4	127
4		HSS4X4X1/4	7	127
5		HSS4X4X1/4	2	179
6		HSS4X4X1/4	1	25
7		HSS4X4X1/4	2	25
8		HSS4X4X1/4	1	179
9	MCMASTER #6111K249	SWIVEL LEVELING MOUNT	8	
10	07_BLOCK FOR FEET	2X4X4 STEEL PLATE	8	
11		L1X1X1/8	8	179
12		HSS3X2X1/4	4	179

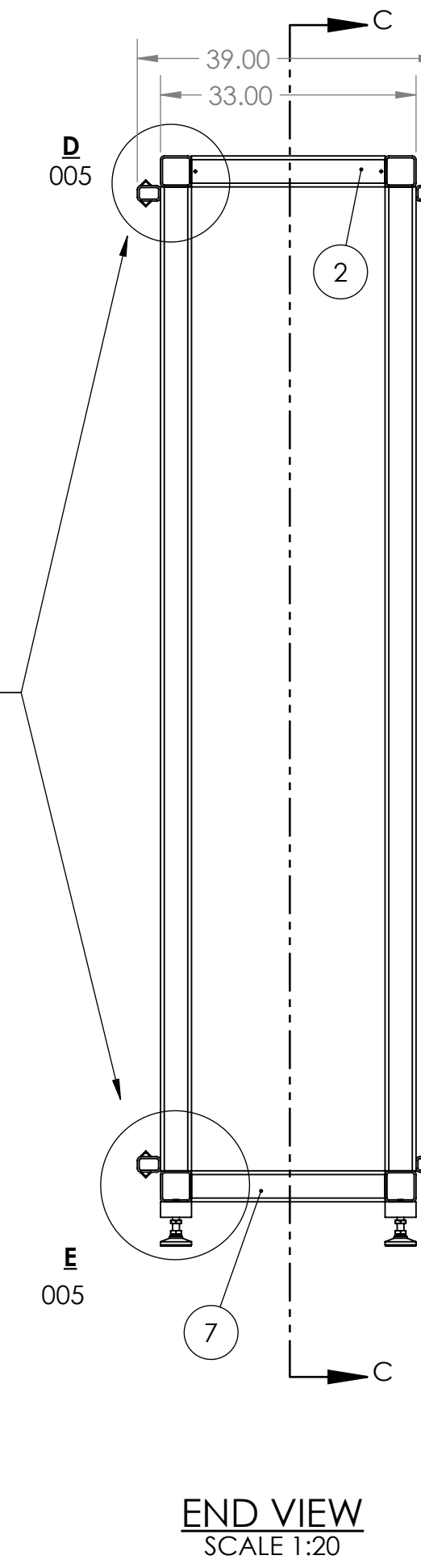
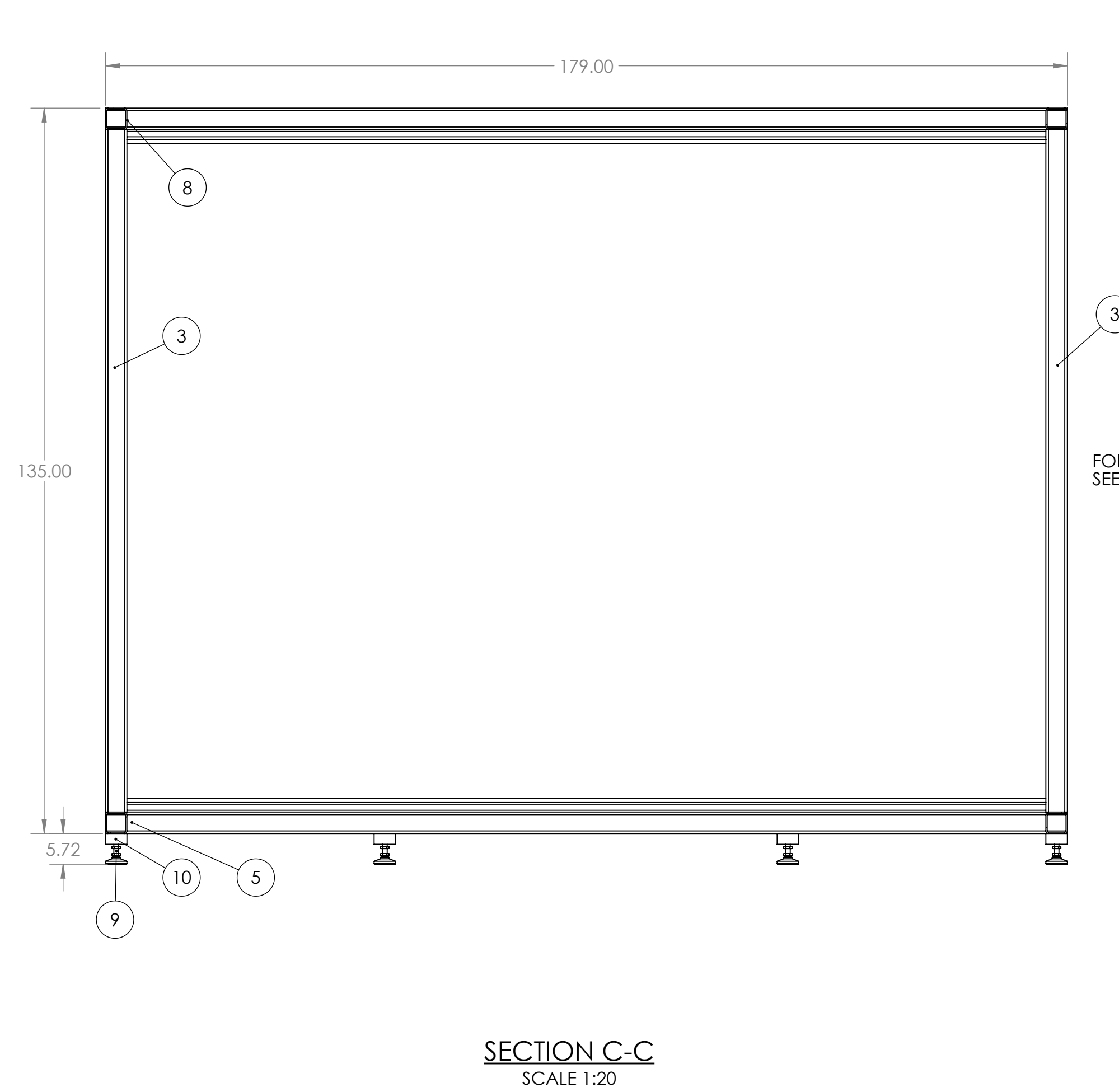
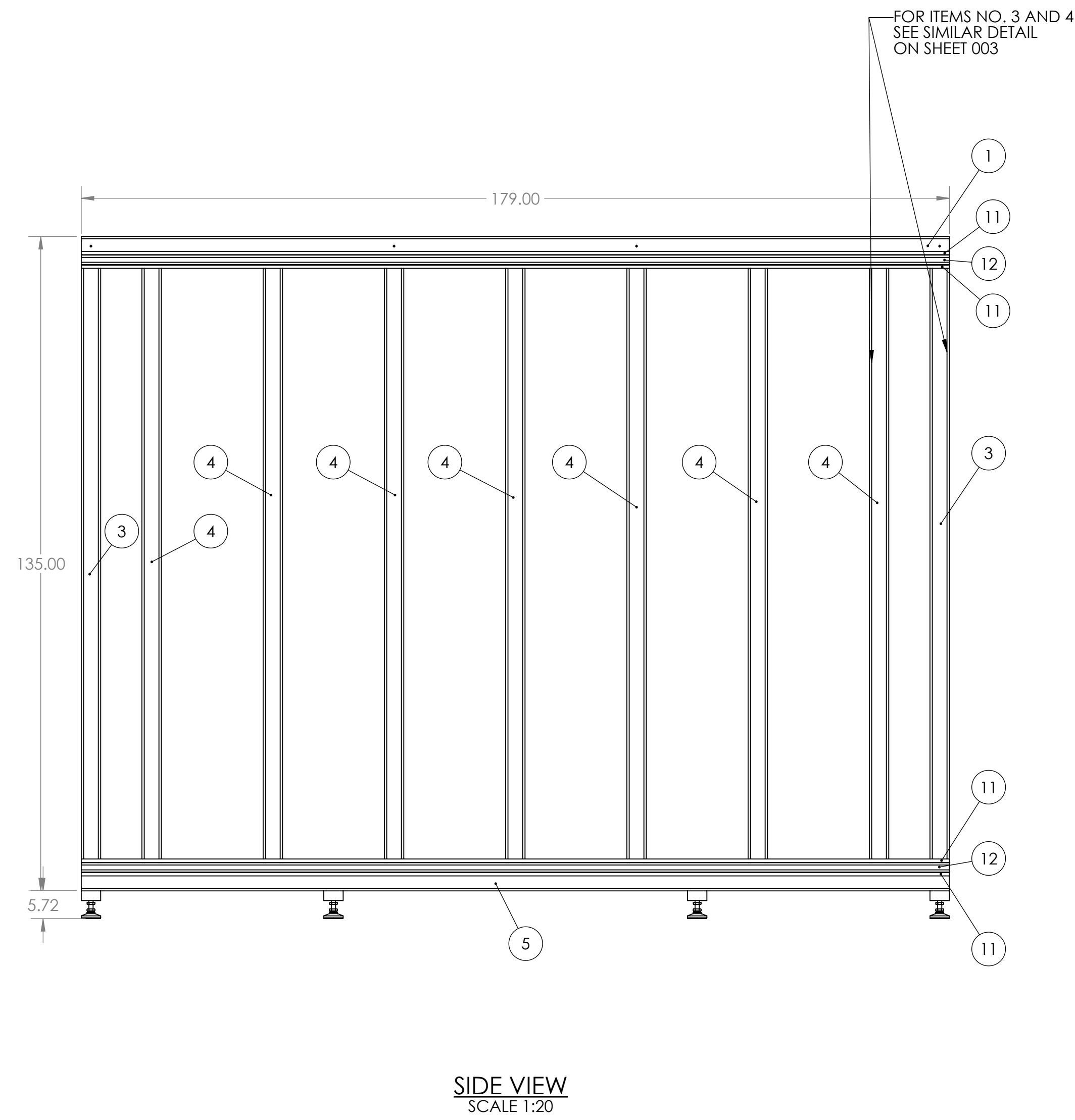
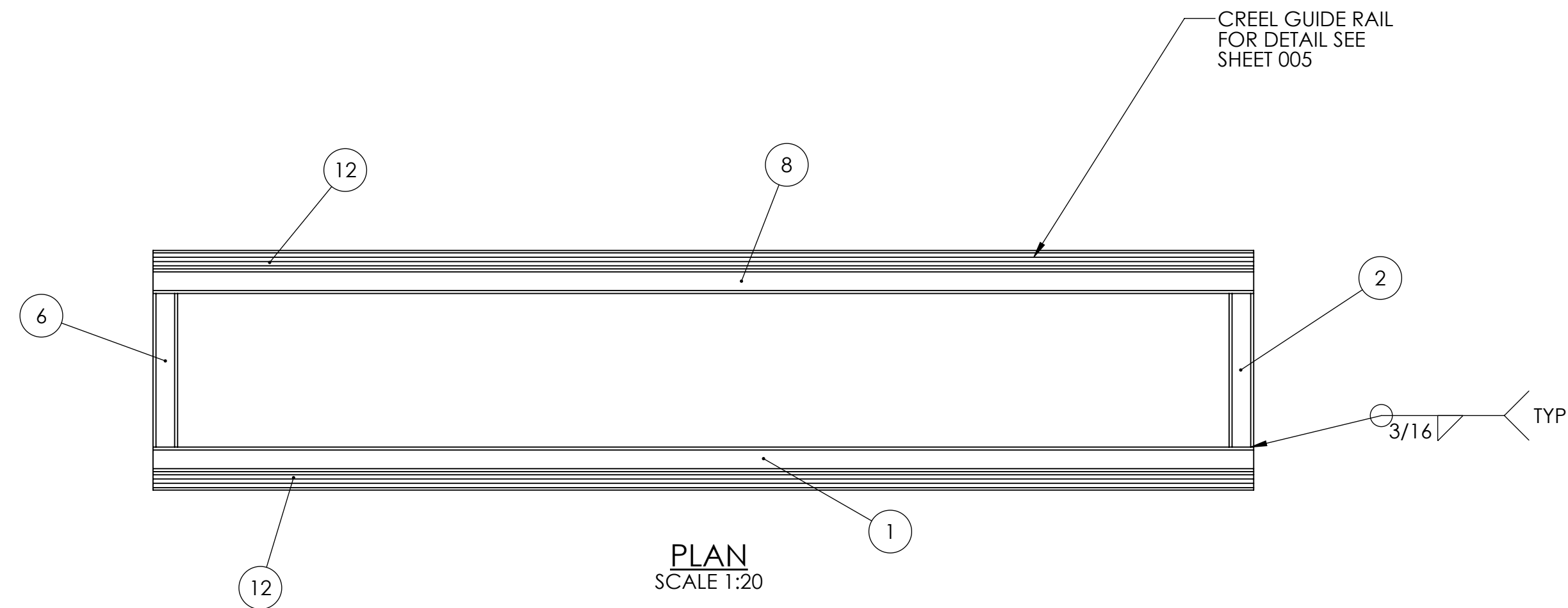

NO.	REVISIONS	DATE	APPROVED BY:
0	RELEASED FOR QUOTE	12/18/2025	PJ

TITLE:		
CFM GEN 3.0 CENTER CREEL		
SCALE: AS NOTED		
PROJ. NO.		
SIZE	SHEET NO.	REV
D	004	0

CONFIDENTIAL INFORMATION: DO NOT DISTRIBUTE
 THE INFORMATION CONTAINED IN THIS DRAWING IS THE SOLE PROPERTY OF THE UNIVERSITY OF MAINE. ANY REPRODUCTION IN PART OR AS A WHOLE WITHOUT THE WRITTEN PERMISSION OF THE UNIVERSITY OF MAINE IS PROHIBITED.

NOTES:
 HSS4x4x1/4 FOR ALL STEEL MEMBERS.

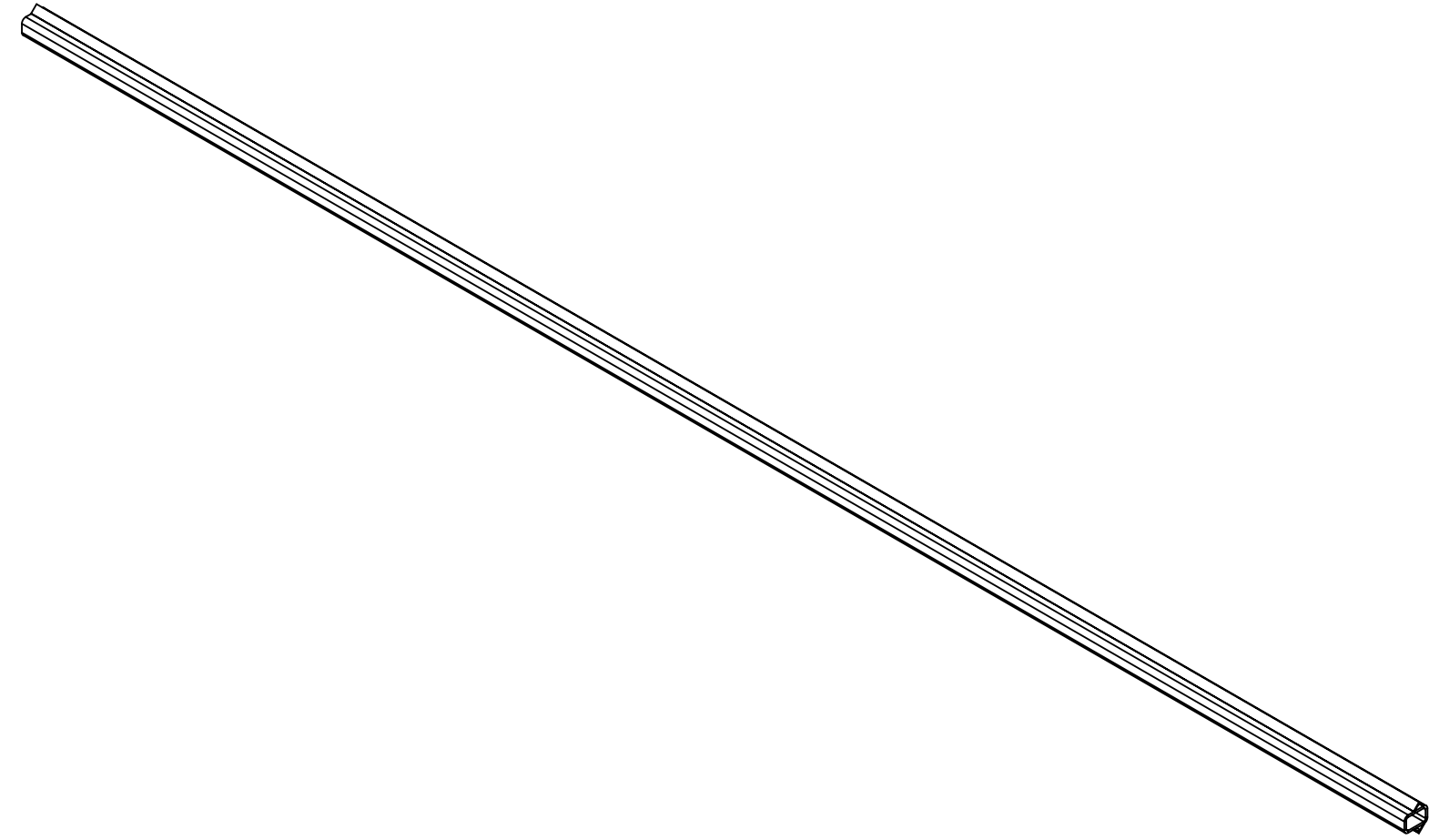
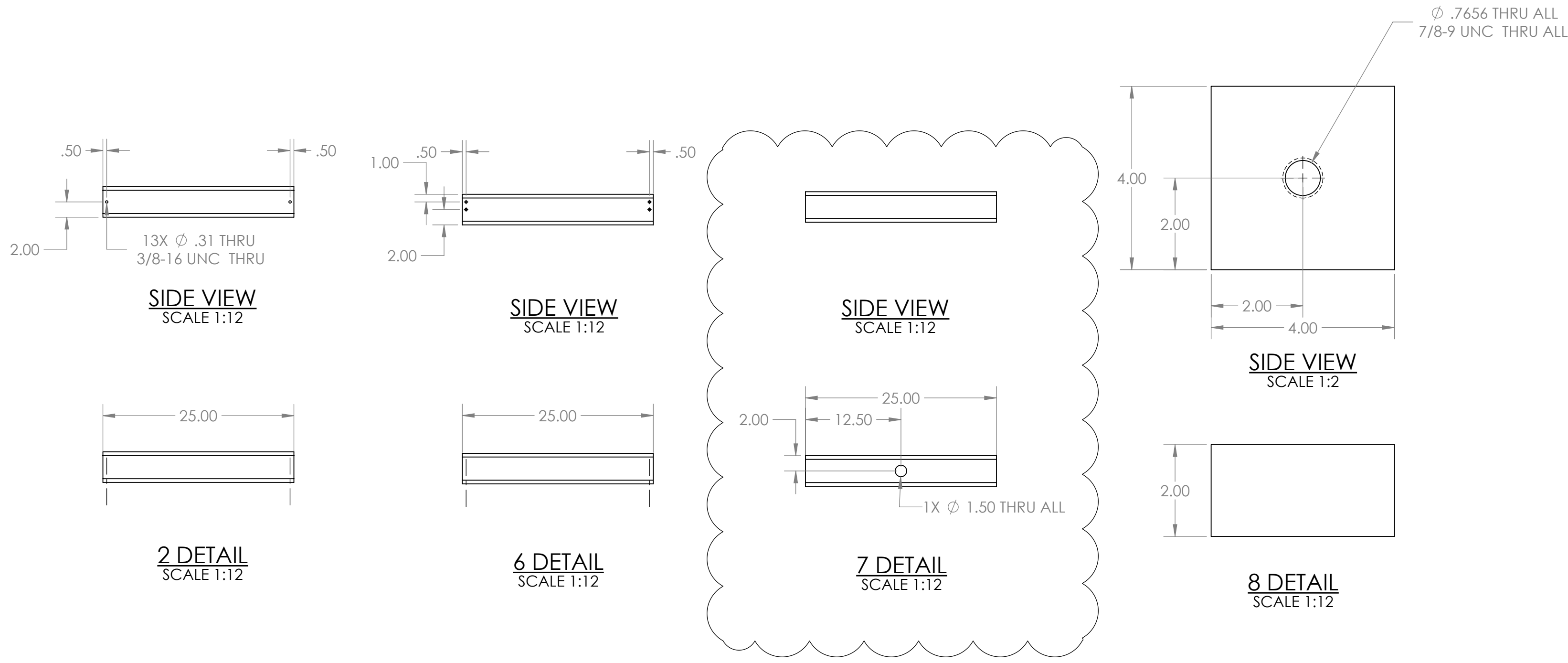

GUIDE ASSEMBLY ISOMETRIC SCALE 1:1

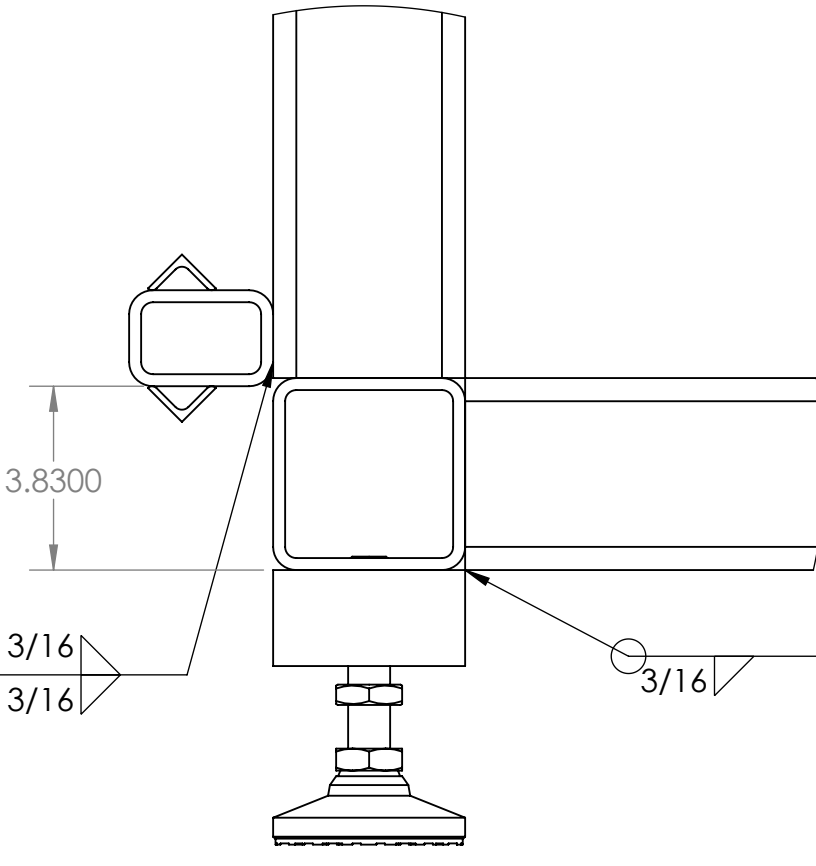
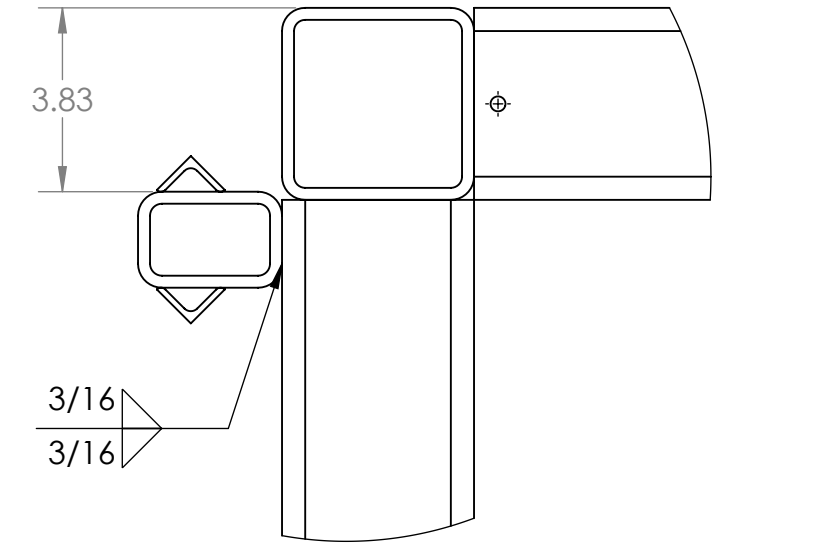
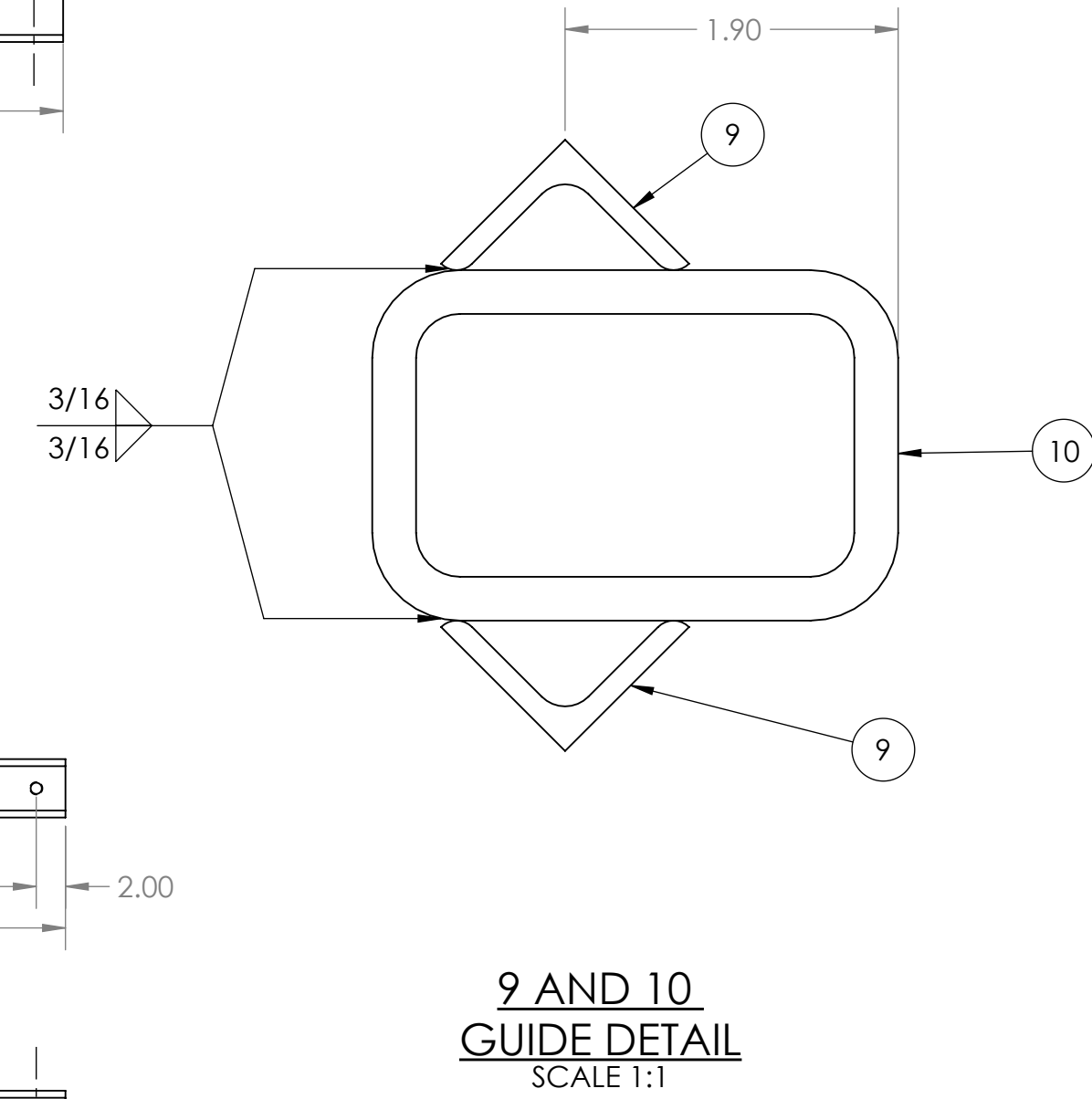
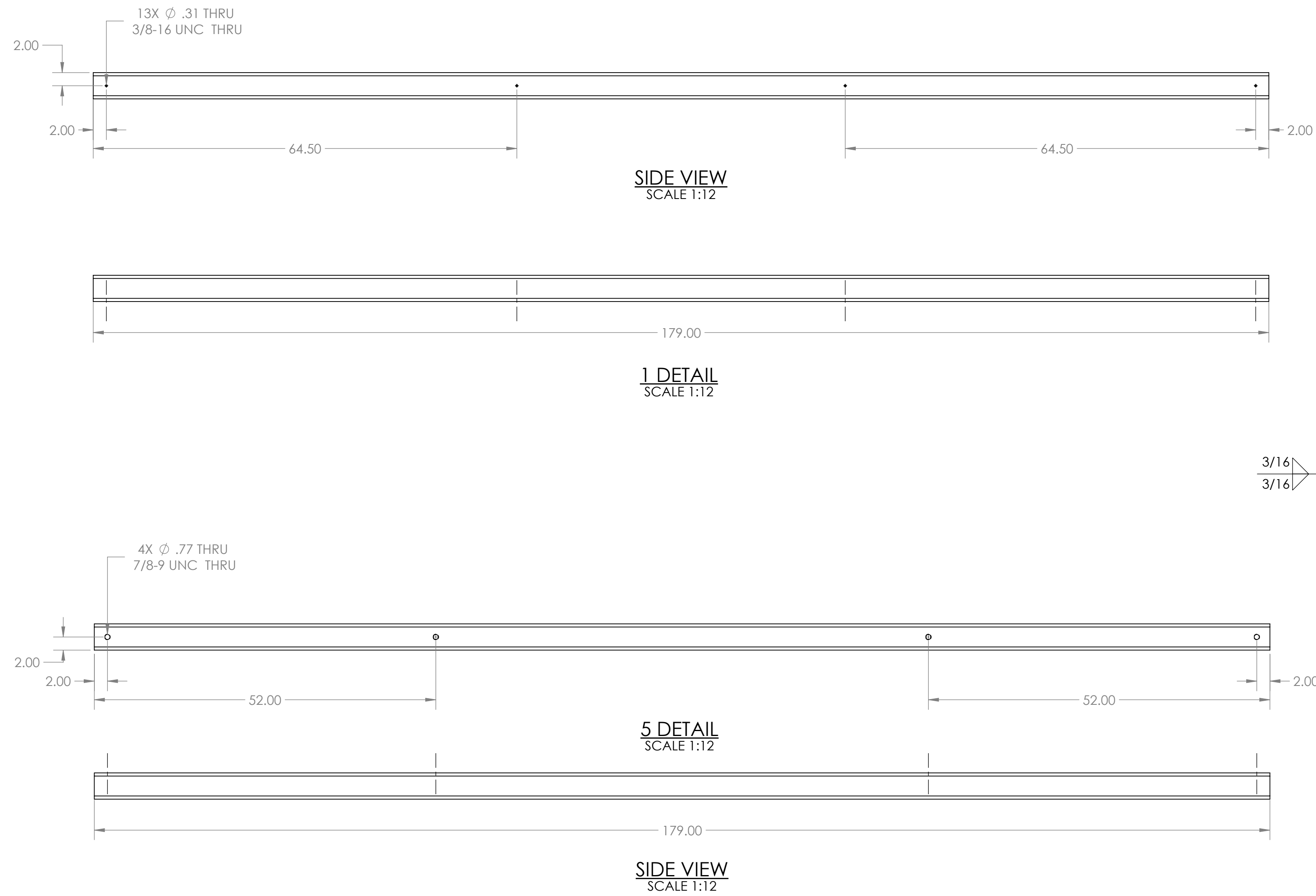

NO.	REVISIONS	DATE	APPROVED BY:
1	ADDED MOUNTING HOLES	1/13/2026	PJ
0	RELEASED FOR QUOTE	12/18/2025	PJ

TITLE:
 CFM GEN 3.0
 CENTER CREEL
 DETAIL I & GUIDE DETAILS

SCALE: AS NOTED

PROJ. NO.

SIZE	SHEET NO.	REV
D	005	1

CONFIDENTIAL INFORMATION: DO NOT DISTRIBUTE
 THE INFORMATION CONTAINED IN THIS DRAWING IS THE SOLE PROPERTY OF THE UNIVERSITY OF MAINE. ANY REPRODUCTION IN PART OR AS A WHOLE WITHOUT THE WRITTEN PERMISSION OF THE UNIVERSITY OF MAINE IS PROHIBITED.

NOTES:
 1. 3/16" WELD ALL AROUND.

BOM TABLE/ LEFT SIDE CREEL				
ITEM NO.	PART NUMBER	DESCRIPTION	QTY.	LENGTH
1		HSS4X4X1/4	1	179
2		HSS4X4X1/4	4	35
3		HSS4X4X1/4	4	127
4		HSS4X4X1/4	7	127
5		HSS4X4X1/4	1	179
6		HSS4X4X1/4	1	179
7		HSS4X4X1/4	1	179
8	07_WHEEL PLATE	1/8 STEEL PLATE	8	
9	MCMASTER #2856T24	HIGH-CAPACITY SPARTAN CASTER WITH 5" X 4" MOUNTING PLATE	8	

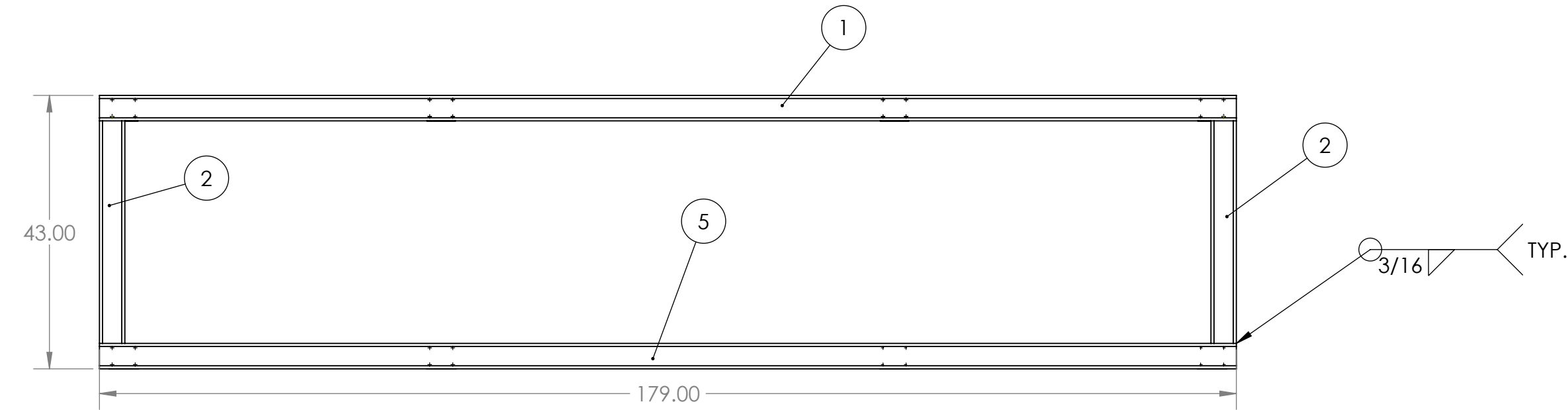

PLAN
 SCALE 1:20

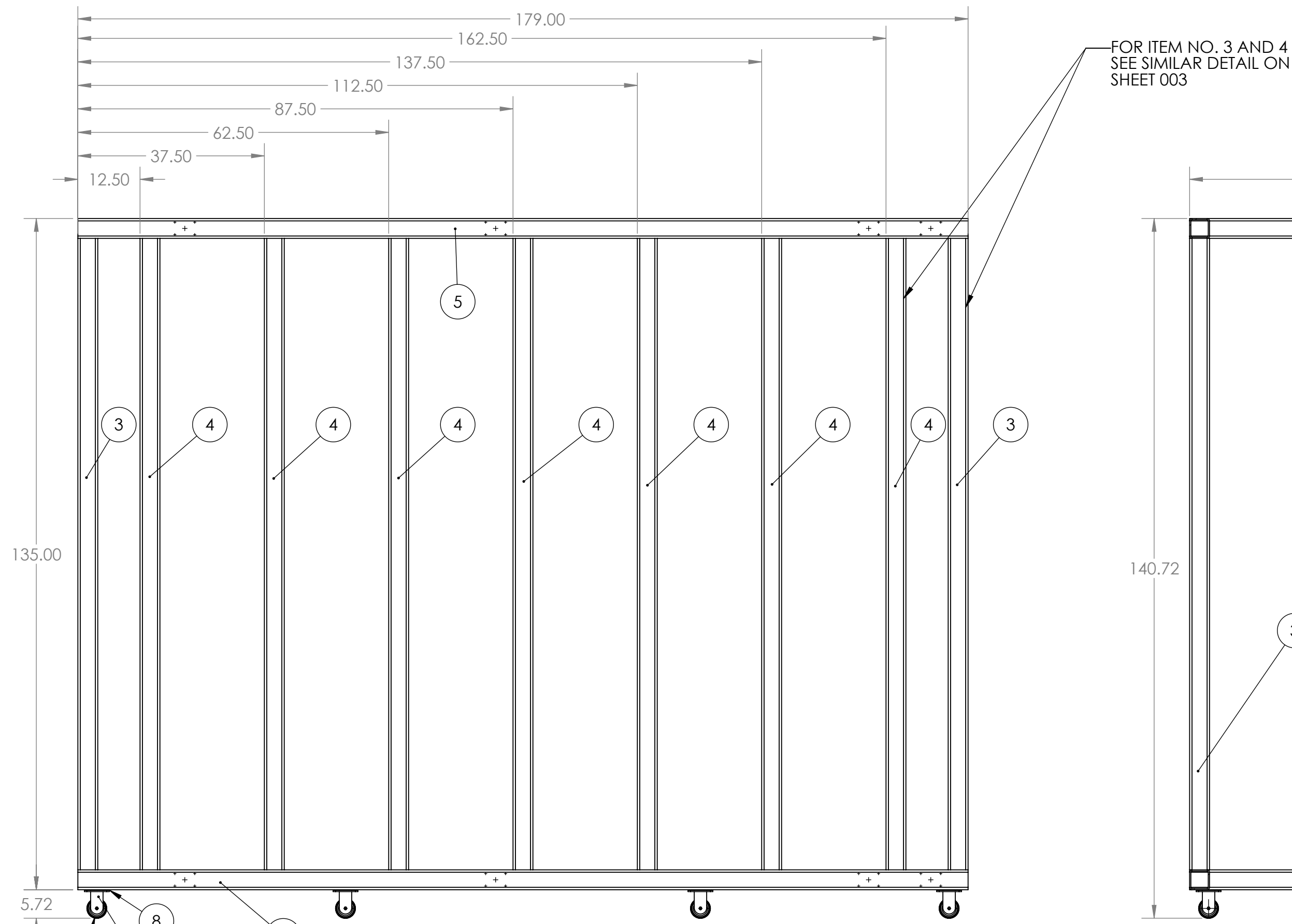

SIDE VIEW
 SCALE 1:20

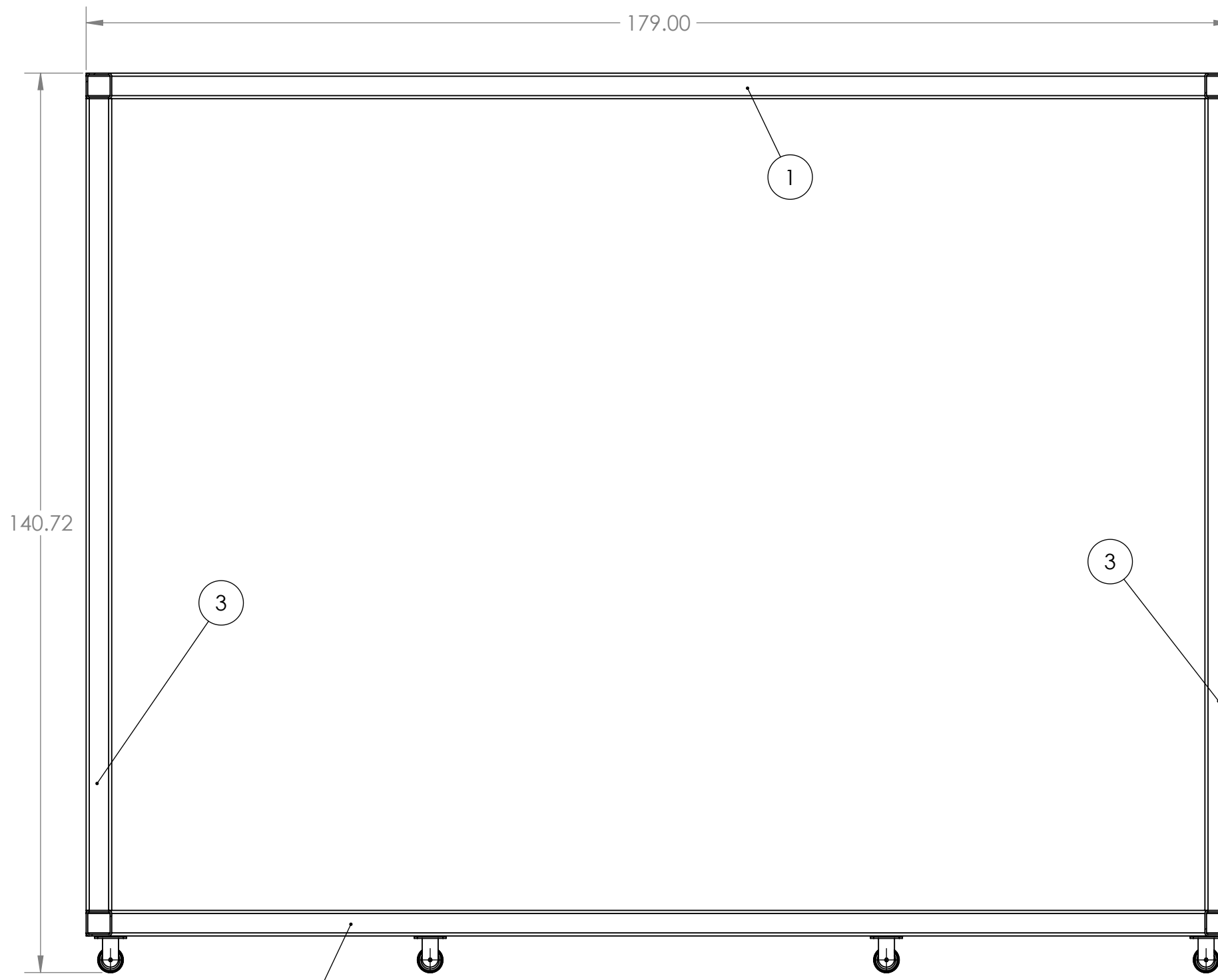

SECTION F-F
 SCALE 1:20

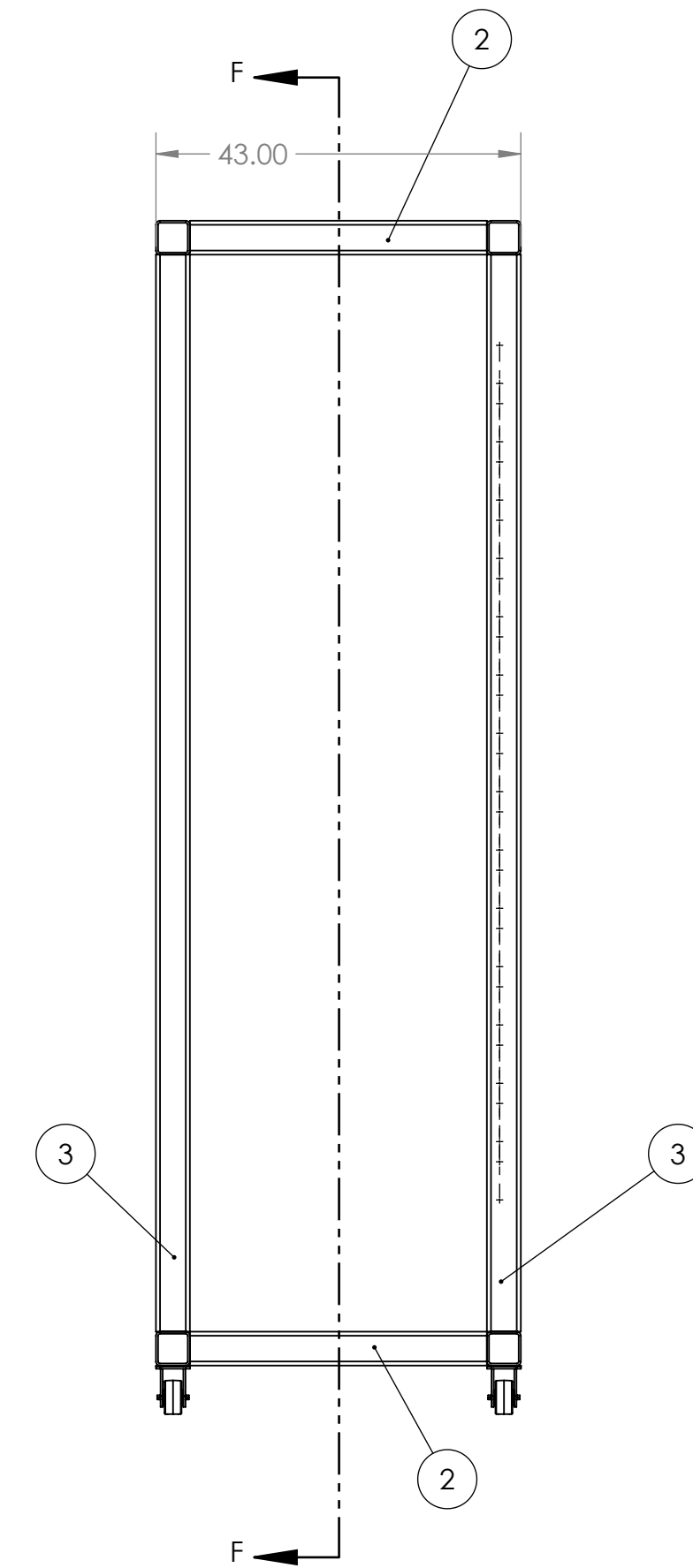

END VIEW
 SCALE 1:20

FILENAME: C:\Users\peterjahren\OneDrive - University of Maine System (1)\Continuous Forming Machine - 10_Gen 3\02_Creel\Creeel Sliding (current)\Creel Drawings

NO.	REVISIONS	DATE	APPROVED BY:
0	RELEASED FOR QUOTE	12/18/2025	PJ
		DATE:	
		APPROVED BY:	

UNLESS OTHERWISE SPECIFIED: DIMENSIONS ARE IN FEET & INCHES

DESIGNED	NAME	DATE
	NP	09/01/2025
DRAWN	NAME	DATE
	JF	10/31/2025
CHECKED	NAME	DATE
	PJ	12/02/2025
APPROVED	NAME	DATE

TITLE:
 CFM GEN 3.0
 LEFT SIDE CREEL

SCALE: AS NOTED

PROJ. NO.

SIZE	SHEET NO.	REV
D	006	0

CONFIDENTIAL INFORMATION: DO NOT DISTRIBUTE
 THE INFORMATION CONTAINED IN THIS DRAWING IS THE SOLE PROPERTY OF THE UNIVERSITY OF MAINE. ANY REPRODUCTION IN PART OR AS A WHOLE WITHOUT THE WRITTEN PERMISSION OF THE UNIVERSITY OF MAINE IS PROHIBITED.

NOTES:
 HSS4x4x1/4 FOR ALL STEEL MEMBERS.

0 RELEASED FOR QUOTE 12/18/2025 PJ

NO. REVISIONS DATE APPROVED BY:

UNLESS OTHERWISE SPECIFIED: DIMENSIONS ARE IN FEET & INCHES

NO.	NAME	DATE
DESIGNED	NP	09/01/2025
DRAWN	JF	10/31/2025
CHECKED	PJ	12/02/2025
APPROVED		

TITLE:
CFM GEN 3.0 LEFT SIDE CREEL DETAILS I

SCALE: AS NOTED

PROJ. NO.

SIZE	SHEET NO.	REV
D	007	0

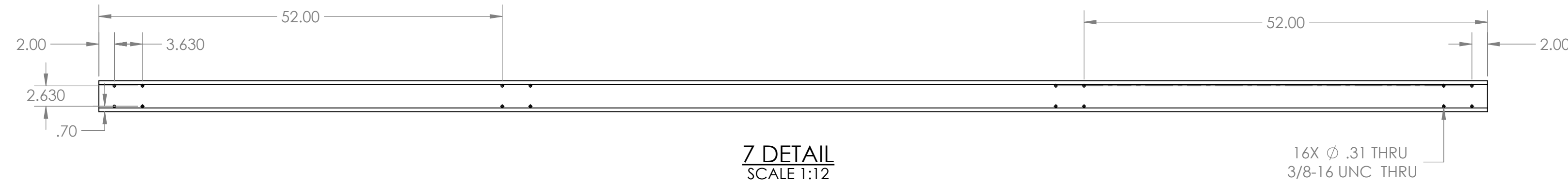
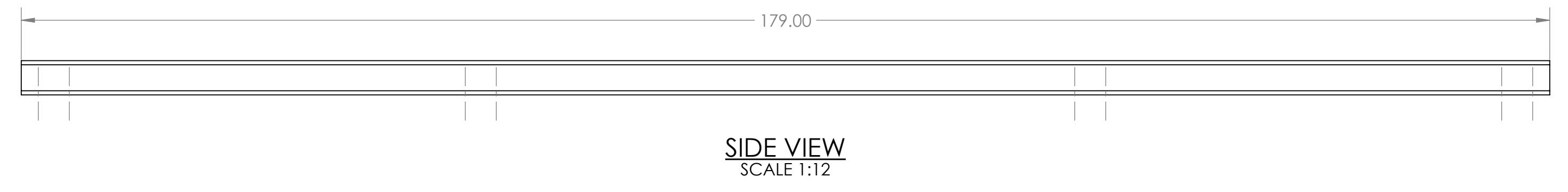
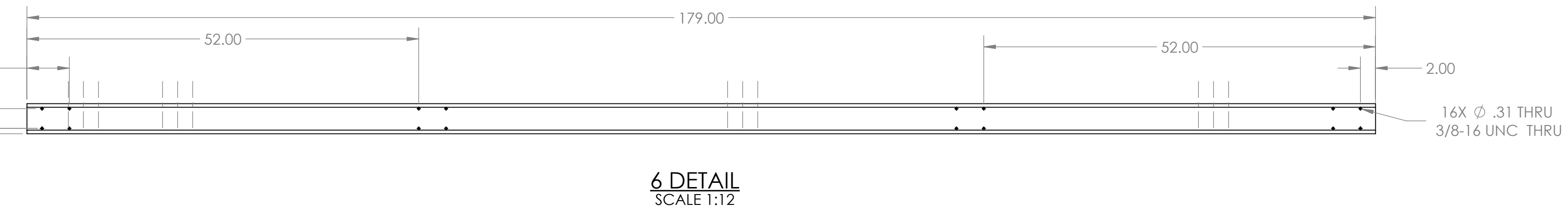
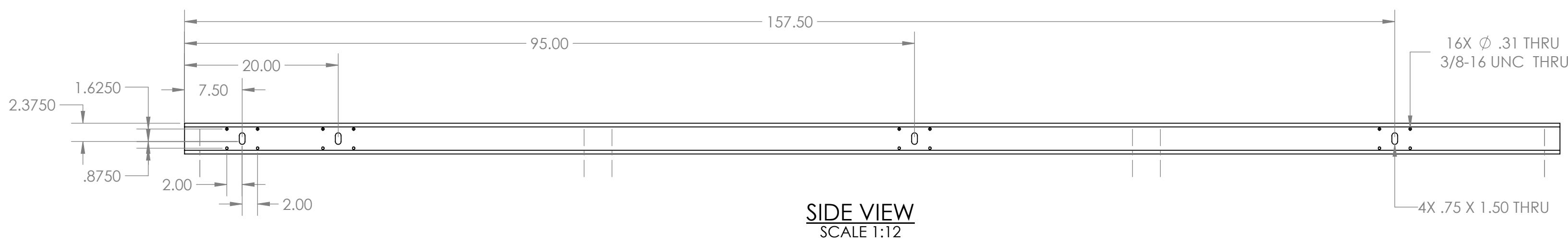
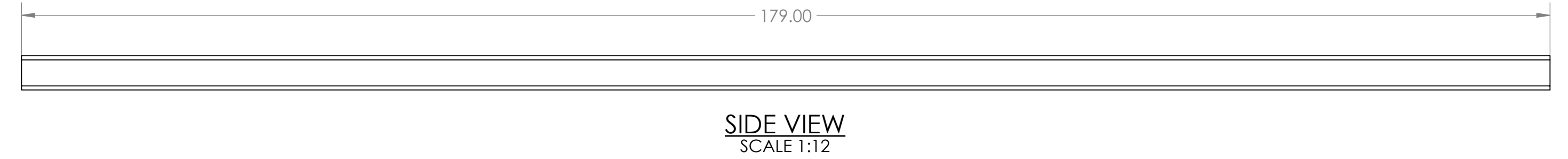
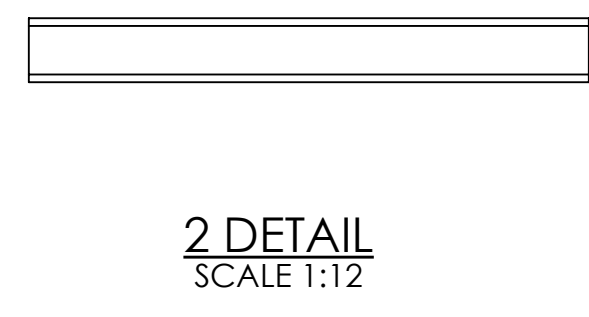
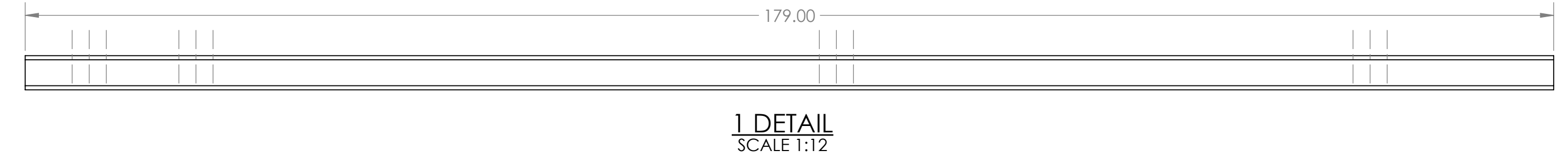
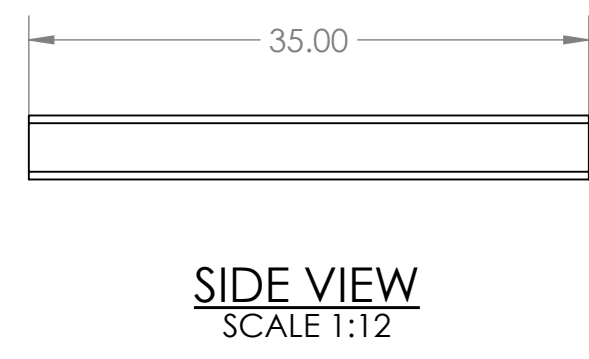
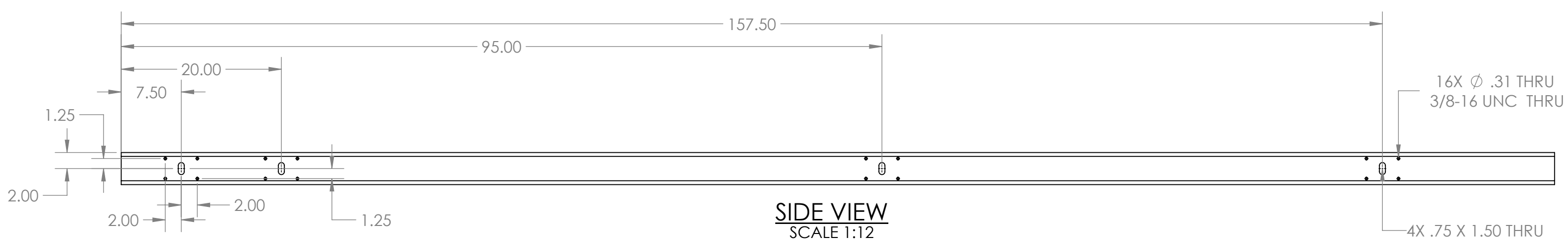

FILENAME: C:\Users\peterjahren\OneDrive - University of Maine System (1)\Continuous Forming Machine - 10_Gen 3\02_Creel\Creeel Sliding (current)\Creeel Drawings

CONFIDENTIAL INFORMATION: DO NOT DISTRIBUTE
 THE INFORMATION CONTAINED IN THIS DRAWING IS THE SOLE PROPERTY OF THE UNIVERSITY OF MAINE. ANY REPRODUCTION IN PART OR AS A WHOLE WITHOUT THE WRITTEN PERMISSION OF THE UNIVERSITY OF MAINE IS PROHIBITED.

NOTES:
 [36] OUTER ARM ASSEMBLIES REQUIRED TOTAL.

BOM TABLE/ OUTER ARM ASSEMBLY			
ITEM NO.	PART NUMBER	DESCRIPTION	QTY.
1	8632T55	D-PROFILE ROTARY SHAFT	1
2	07_PLATE FOR SET SCREW	1/4" STEEL PLATE	1
3	92865A535	MEDIUM-STRENGTH GRADE 5 STEEL HEX HEAD SCREW	1
4		HSS4X4X1/4	1
5		1/4" STEEL PLATE	2
6	95505A605	MEDIUM-STRENGTH STEEL HEX NUT	5
7	91268A655	HIGH-STRENGTH GRADE 8 STEEL HEX HEAD SCREW	5
8	93005A558	FOUR-ARM EXTENDED-TIP THUMB SCREW	2
9	92141A032	18-8 STAINLESS STEEL WASHER	12

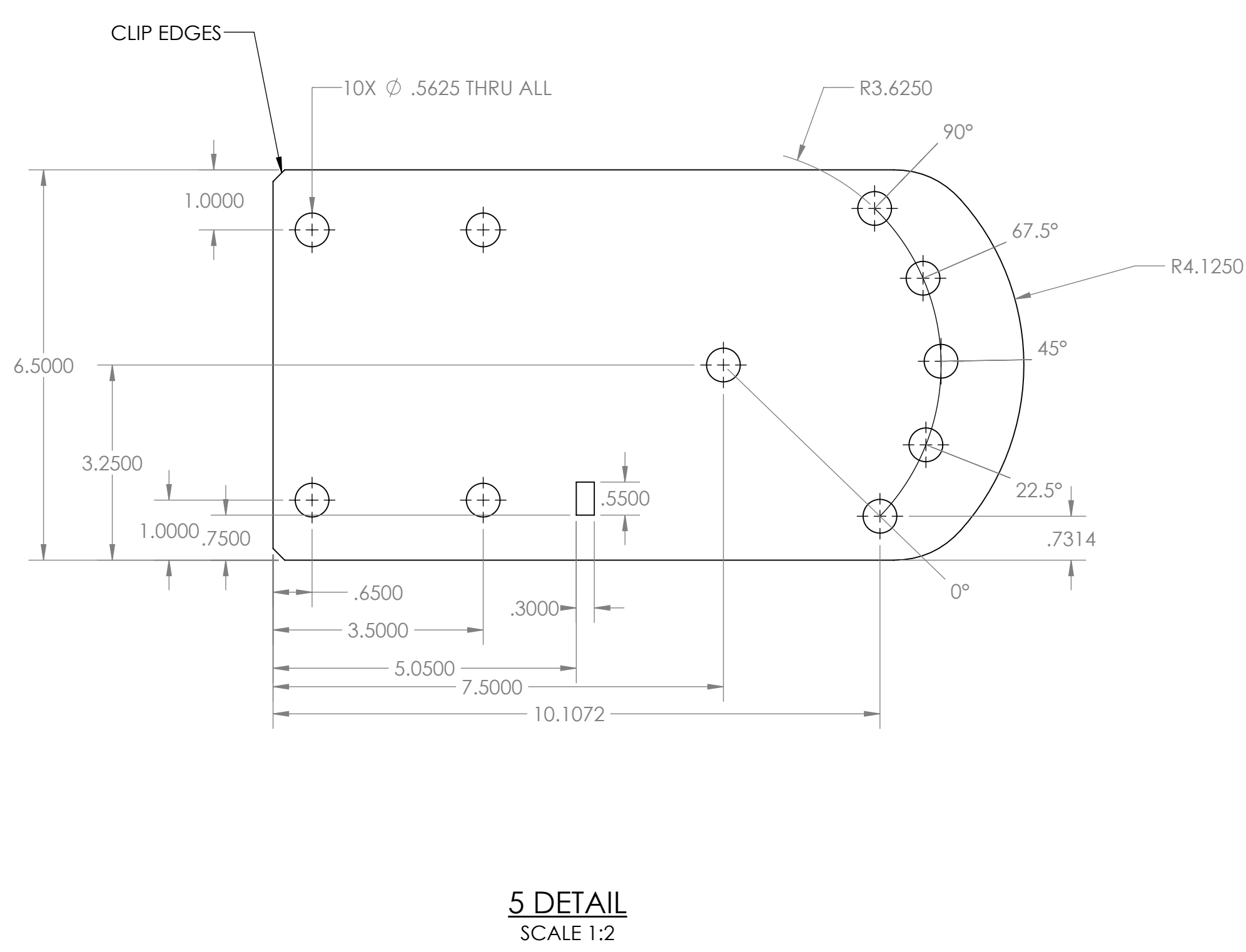
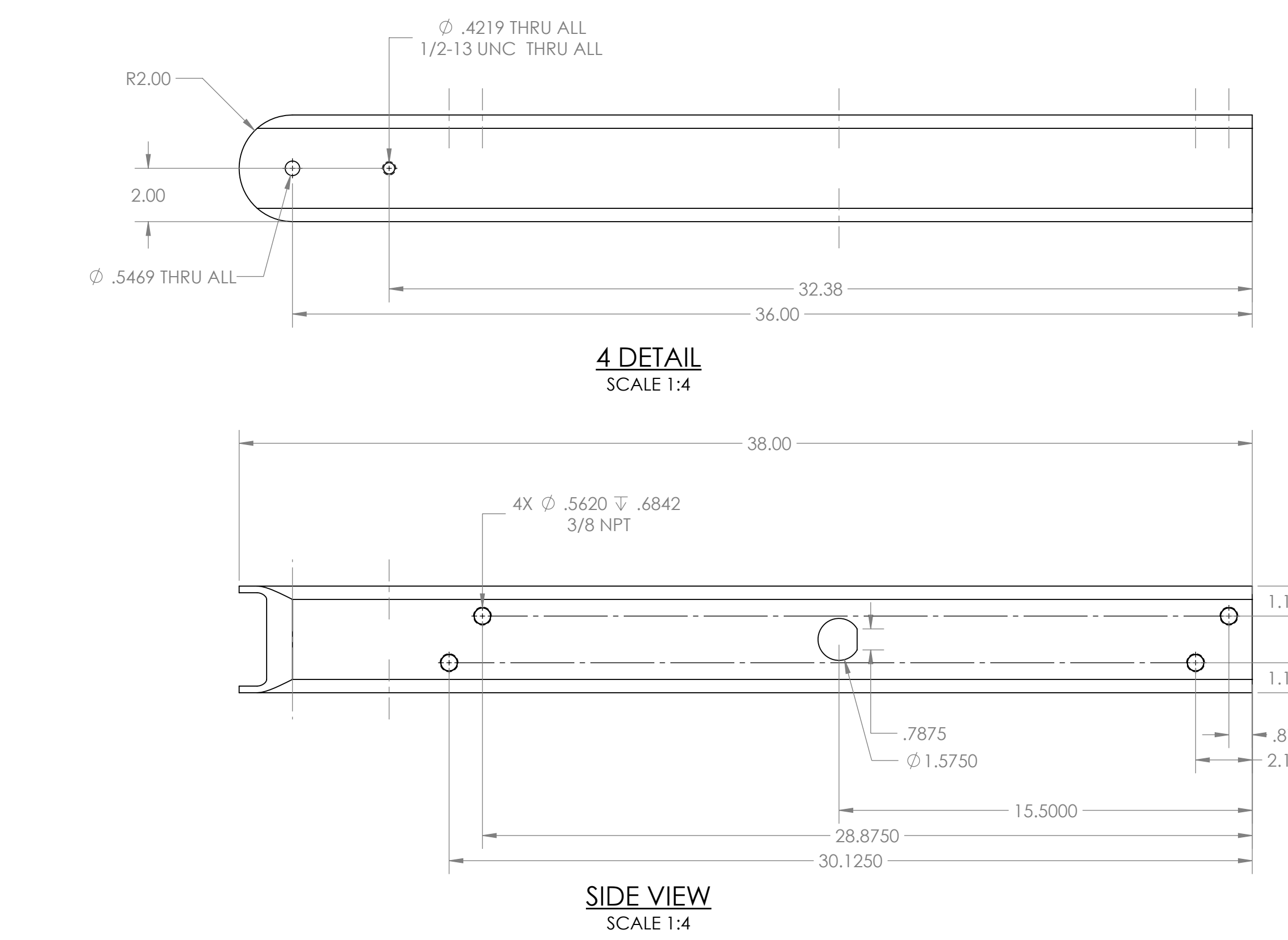
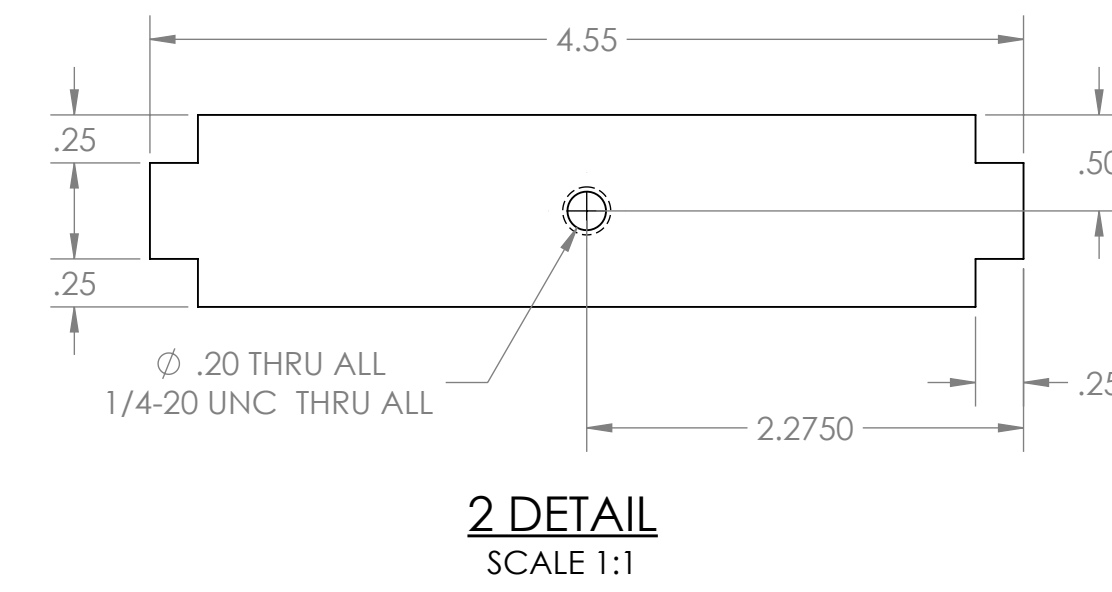
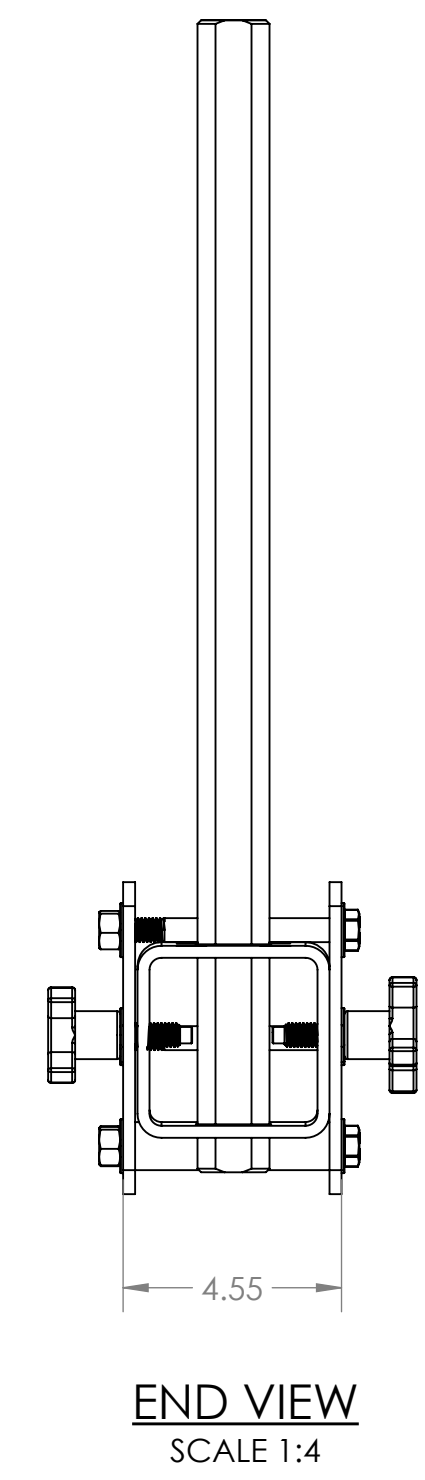
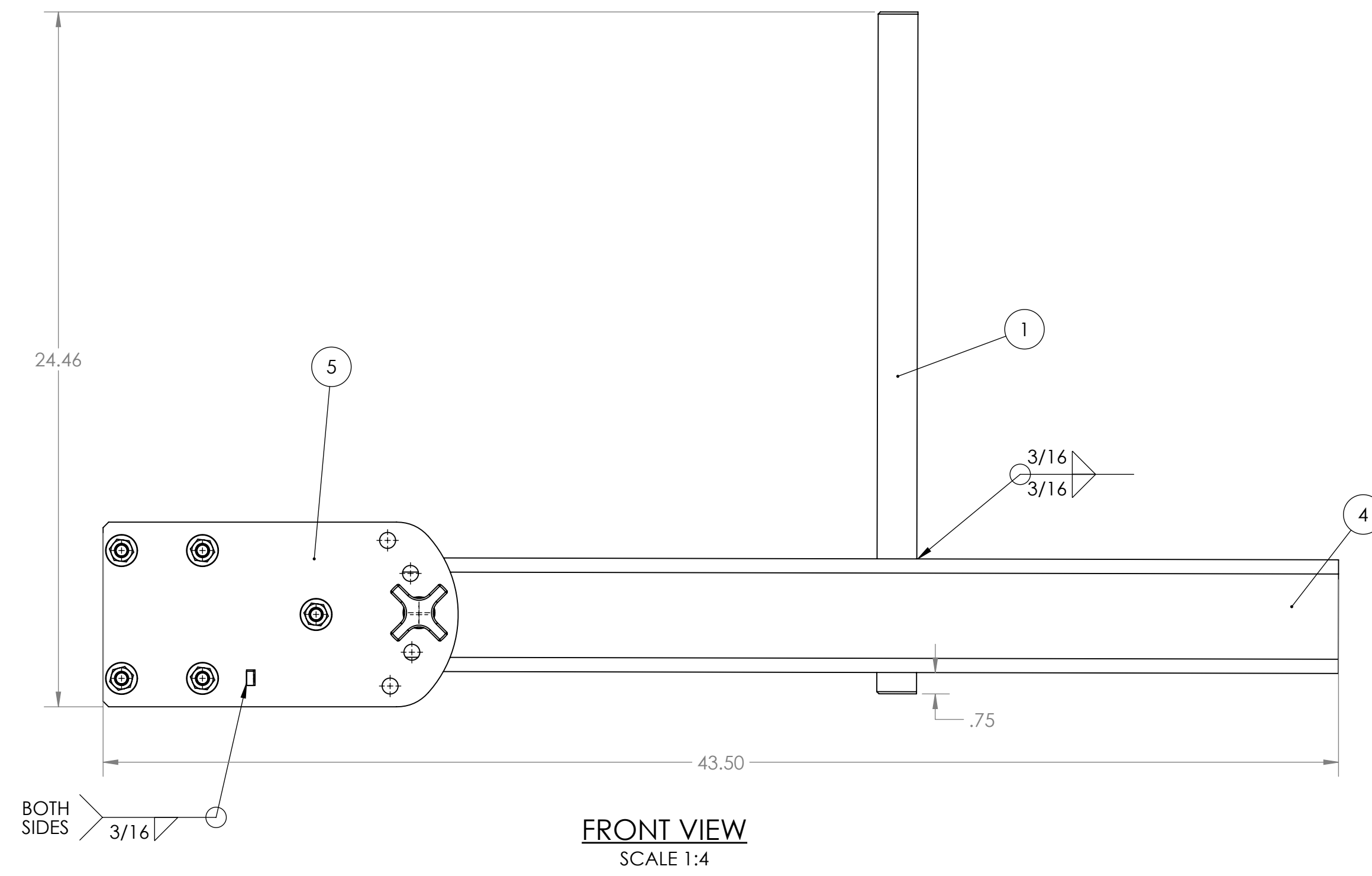
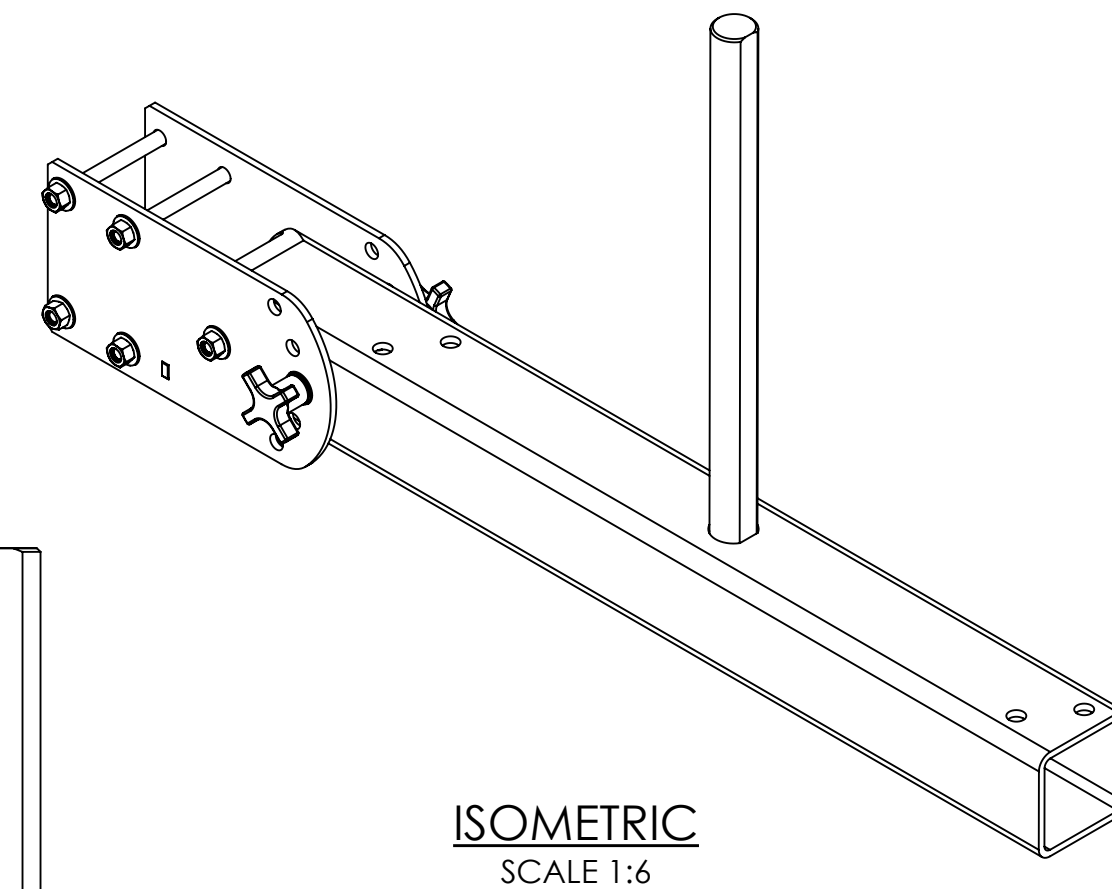
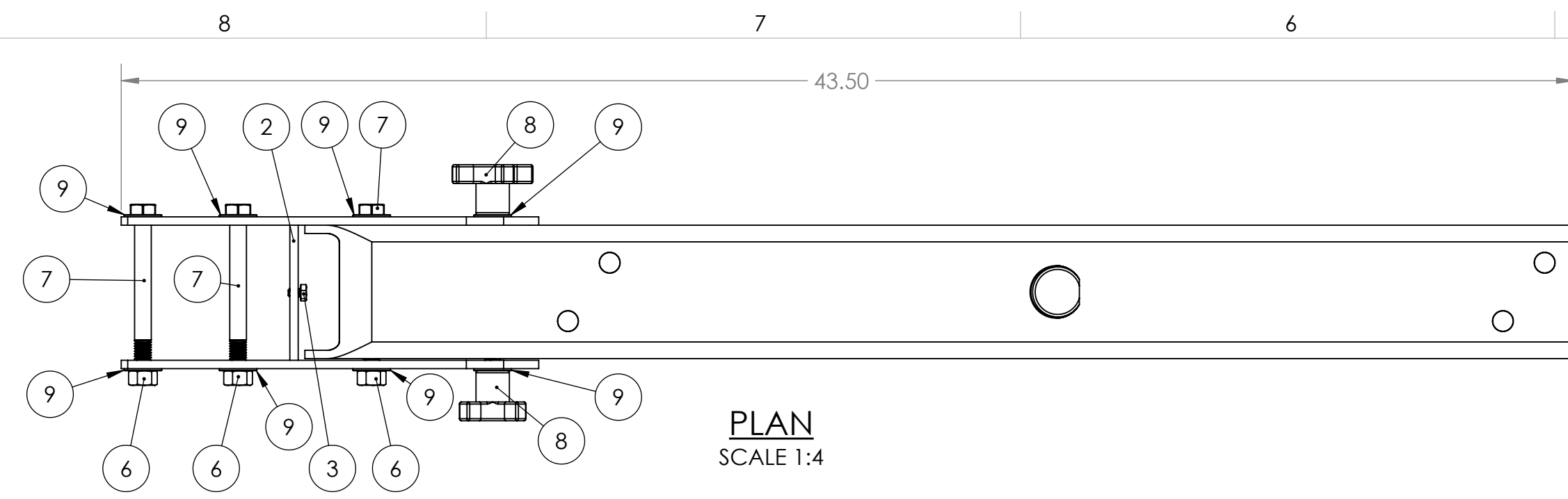

0	RELEASED FOR QUOTE	12/18/2025
		PJ
		DATE:
NO.	REVISIONS	APPROVED BY:
UNLESS OTHERWISE SPECIFIED: DIMENSIONS ARE IN FEET & INCHES		
DESIGNED	NP	09/01/2025
DRAWN	JF	10/31/2025
CHECKED	PJ	12/02/2025
APPROVED		

TITLE:
 CFM GEN 3.0
 OUTER ARM ASSEMBLY

SCALE: AS NOTED

PROJ. NO.

SIZE	SHEET NO.	REV
D	009	0

BOM TABLE/ INNER ARM ASSEMBLY			
ITEM NO.	PART NUMBER	DESCRIPTION	QTY.
1	07_INNER ARM BRACKET	1/4" STEEL PLATE	2
2	8632T55	D-PROFILE ROTARY SHAFT	1
3	07_PIPE HOLDER	1/4" STEEL PLATE	2
4	07_PLATE FOR SET SCREW	1/4" STEEL PLATE	1
5	91268A655	HIGH-STRENGTH GRADE 8 STEEL HEX HEAD SCREW	4
6	95505A605	MEDIUM-STRENGTH STEEL HEX NUT	4
7	92141A032	18-8 STAINLESS STEEL WASHER	8

CONFIDENTIAL INFORMATION: DO NOT DISTRIBUTE
 THE INFORMATION CONTAINED IN THIS DRAWING IS THE SOLE PROPERTY OF THE UNIVERSITY OF MAINE. ANY REPRODUCTION IN PART OR AS A WHOLE WITHOUT THE WRITTEN PERMISSION OF THE UNIVERSITY OF MAINE IS PROHIBITED.

NOTES:
 [24] INNER ARM ASSEMBLIES REQUIRED TOTAL.

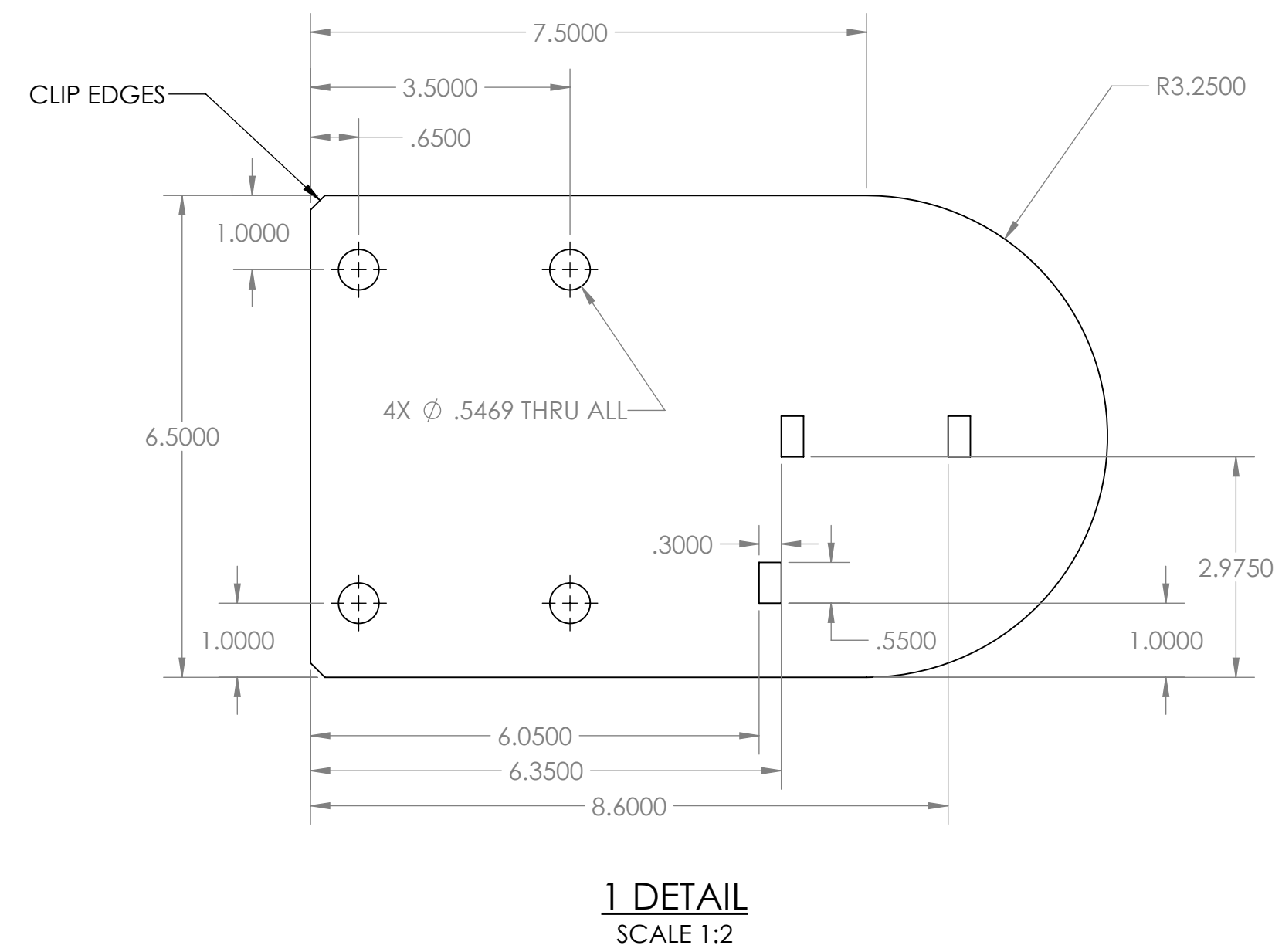
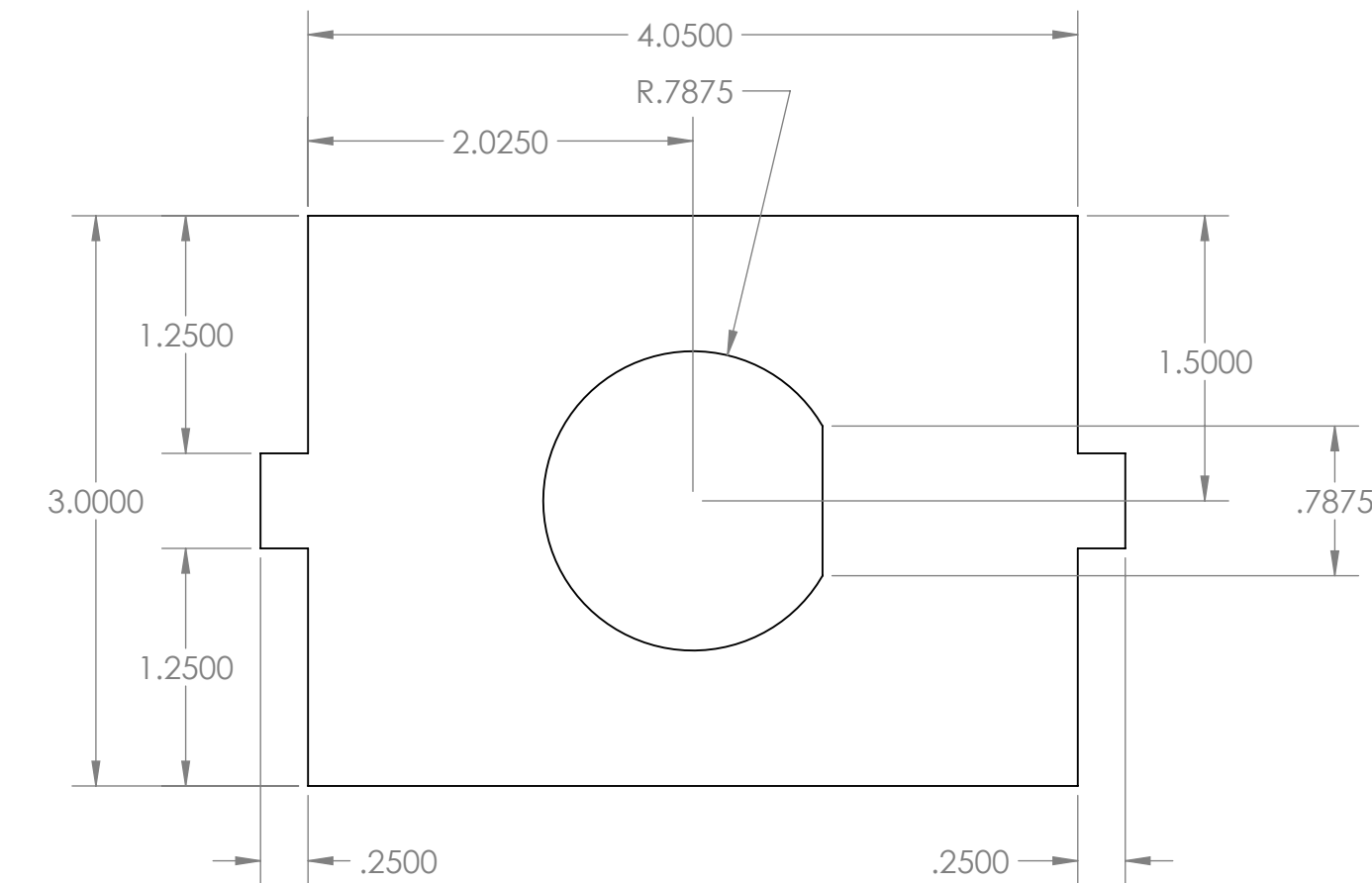
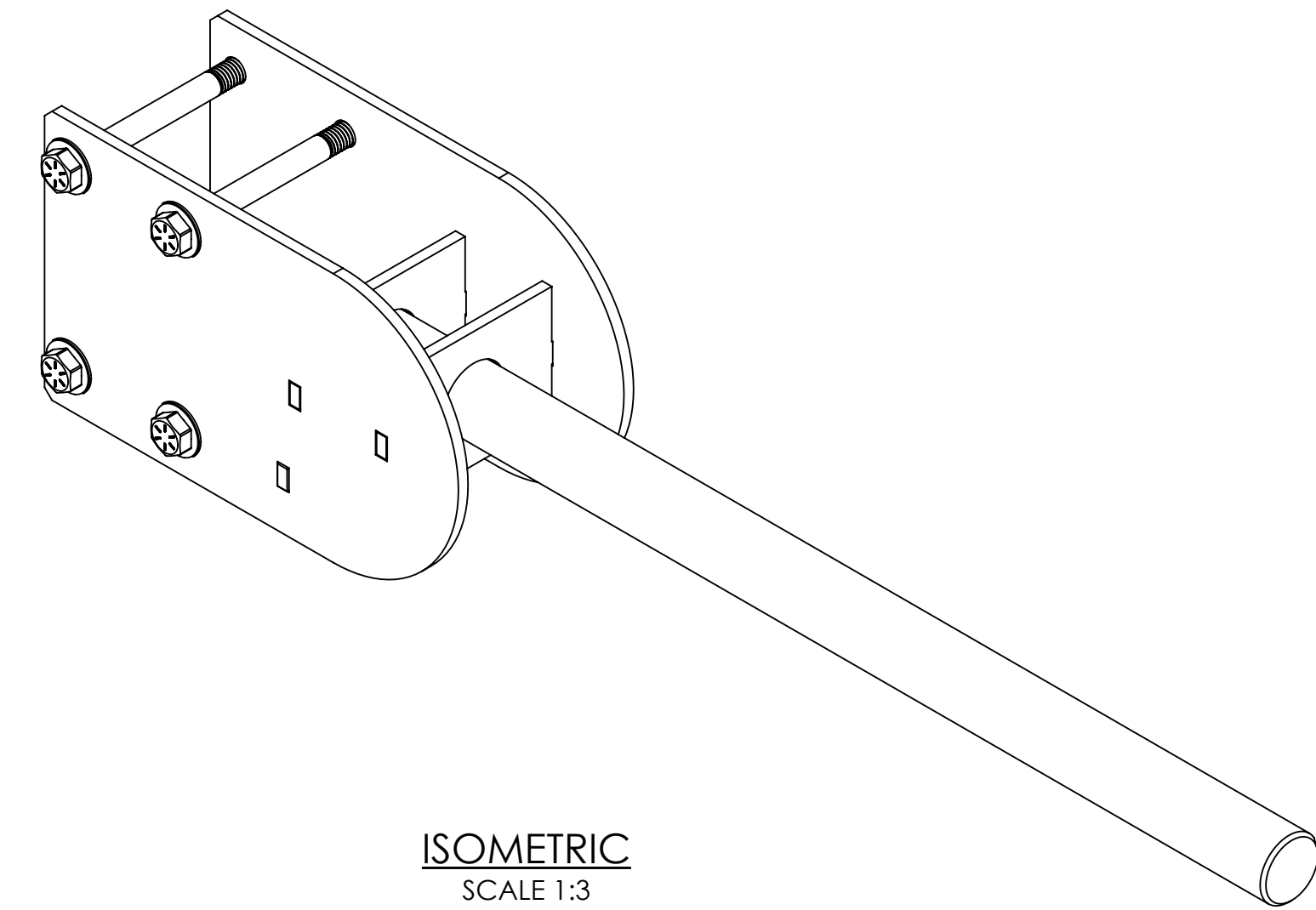
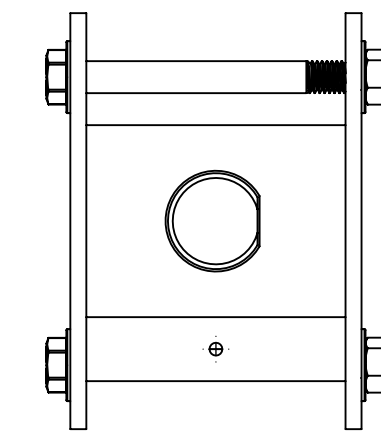
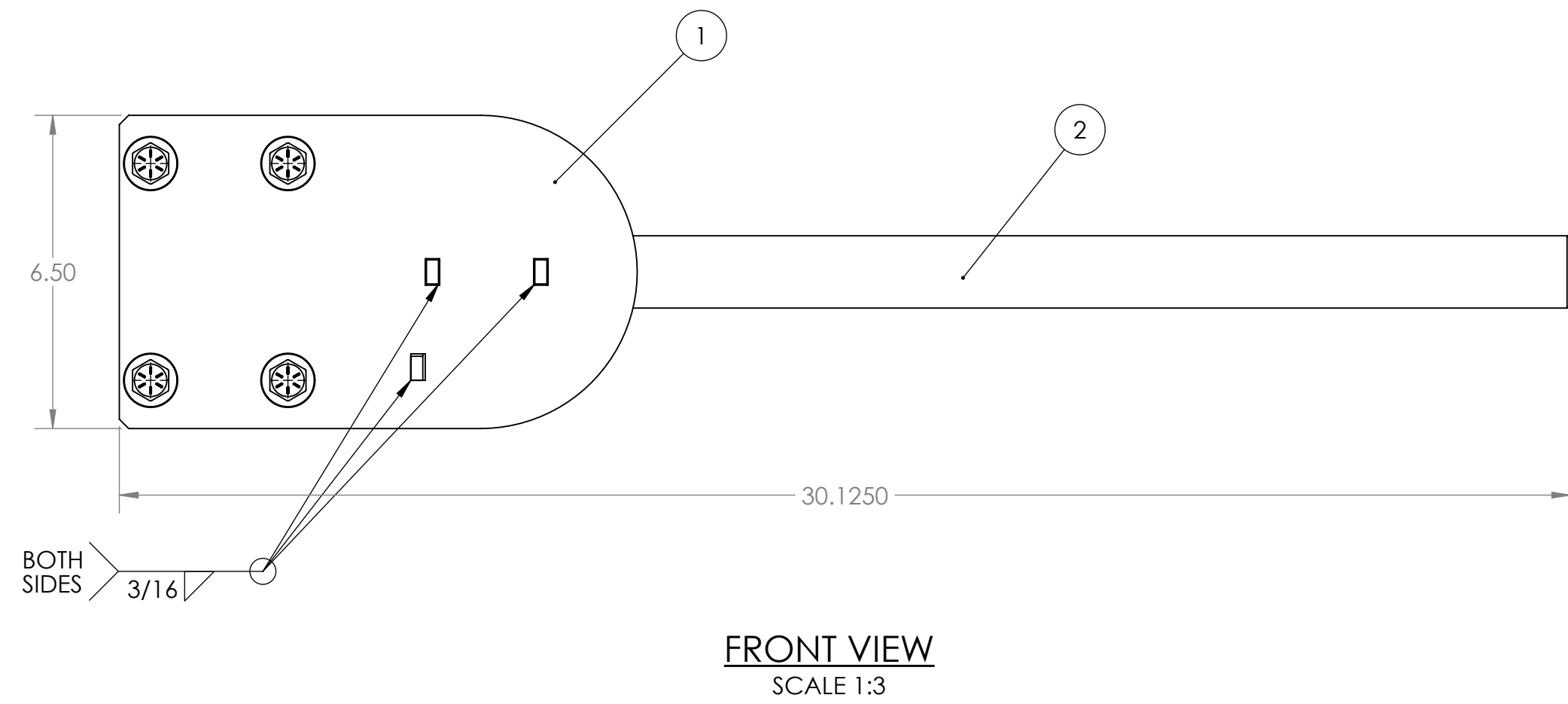
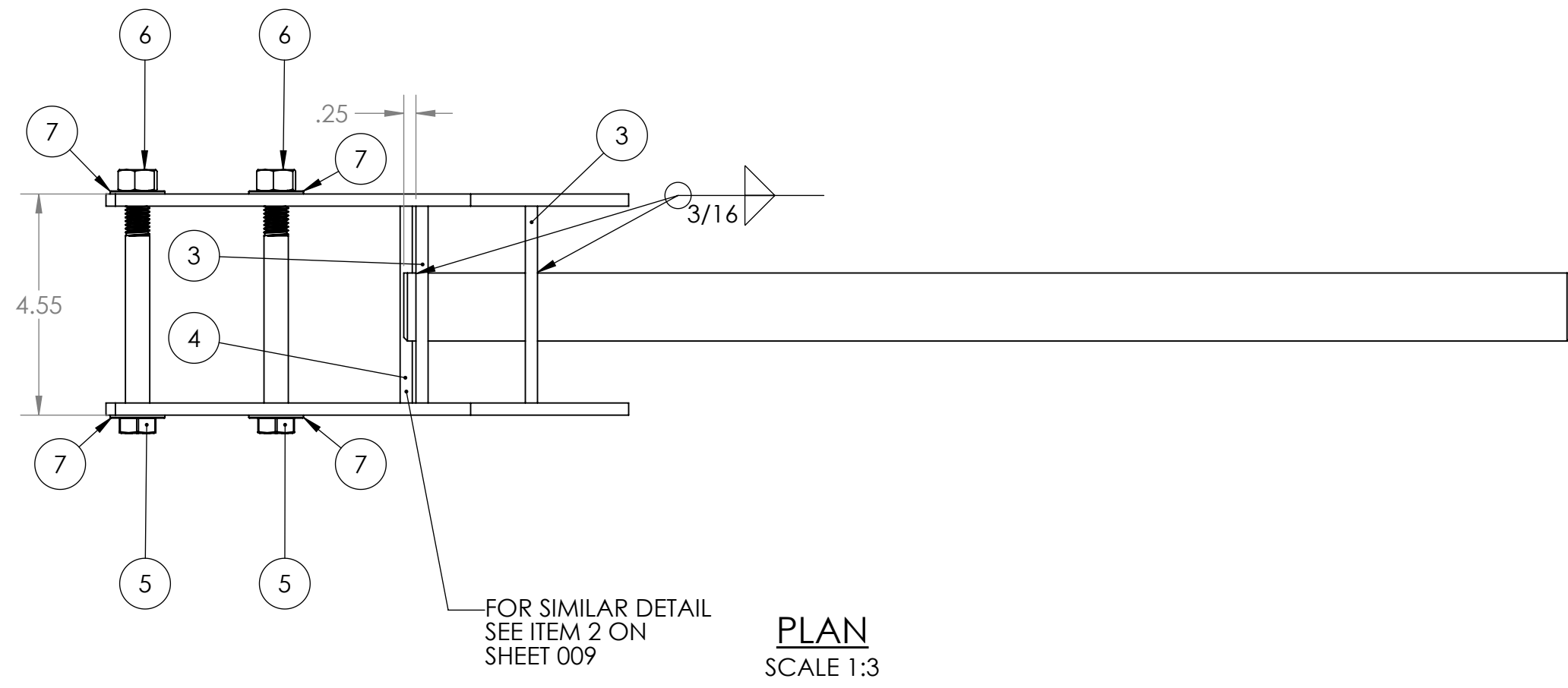

0	RELEASED FOR QUOTE	12/18/2025
		PJ
		DATE:
NO.	REVISIONS	APPROVED BY:
UNLESS OTHERWISE SPECIFIED: DIMENSIONS ARE IN FEET & INCHES		
DESIGNED	NAME NP	DATE 09/01/2025
DRAWN	JF	10/31/2025
CHECKED	PJ	12/02/2025
APPROVED		

TITLE:
 CFM GEN 3.0
 INNER ARM ASSEMBLY

SCALE: AS NOTED

PROJ. NO.

SIZE	SHEET NO.	REV
D	010	0

CONFIDENTIAL INFORMATION: DO NOT DISTRIBUTE
 THE INFORMATION CONTAINED IN THIS DRAWING IS THE SOLE PROPERTY OF THE UNIVERSITY OF MAINE. ANY REPRODUCTION IN PART OR AS A WHOLE WITHOUT THE WRITTEN PERMISSION OF THE UNIVERSITY OF MAINE IS PROHIBITED.

NOTES:
 [30] ROLLER ASSEMBLIES REQUIRED TOTAL.

BOM TABLE/ ROLLER ASSEMBLY			
ITEM NO.	PART NUMBER	DESCRIPTION	QTY.
1	07_ROLLER HOLDER	1/4" STEEL PLATE	2
2	07_ROLLER BRACKET	1/4" STEEL PLATE	2
3	4457K242	3/8 NPT X20"L	2
4	91268A655	HIGH-STRENGTH GRADE 8 STEEL HEX HEAD SCREW	4
5	95505A605	MEDIUM-STRENGTH STEEL HEX NUT	4
6	92141A032	18-8 STAINLESS STEEL WASHER	8

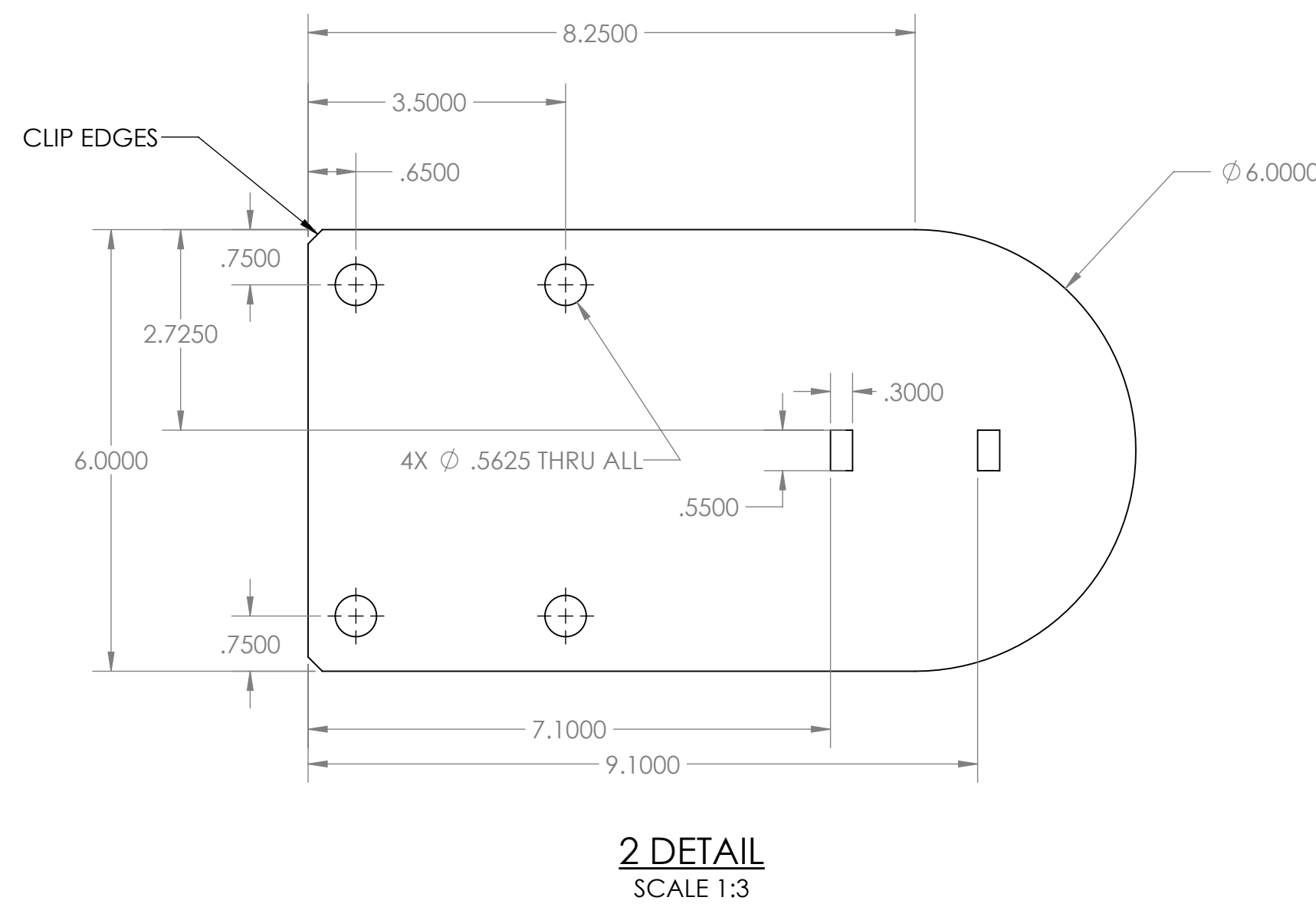
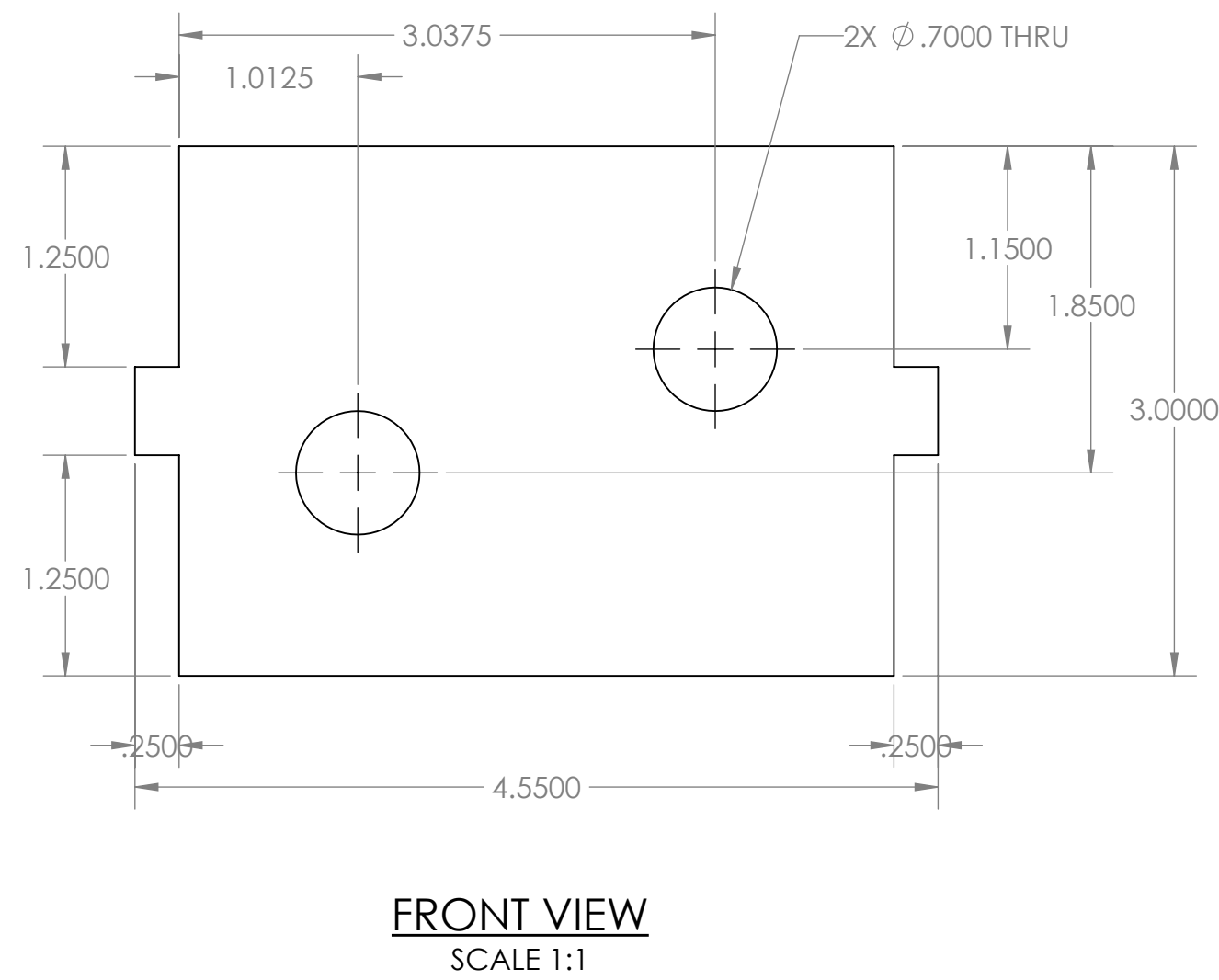
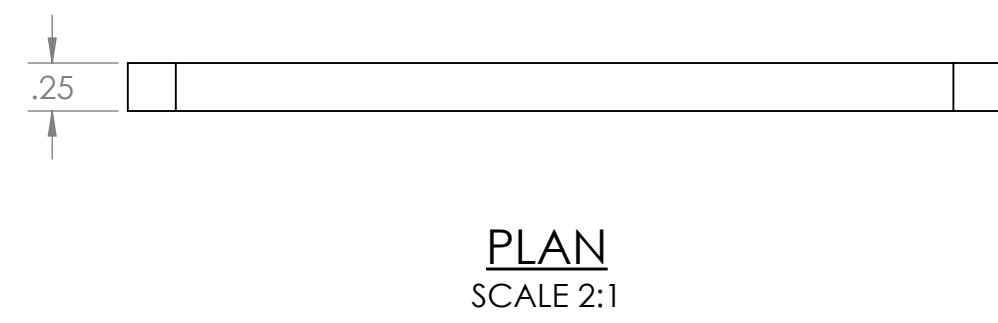
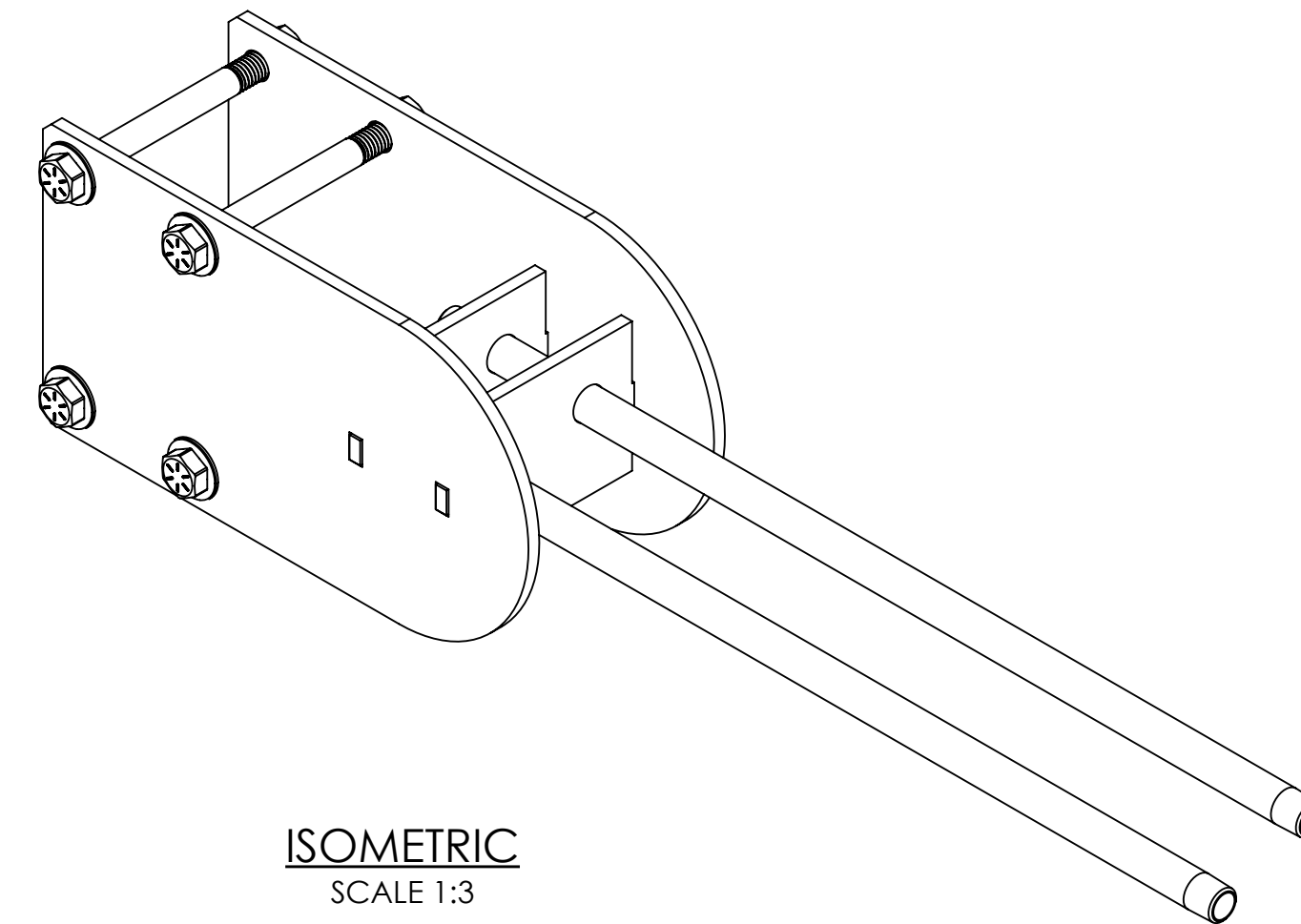
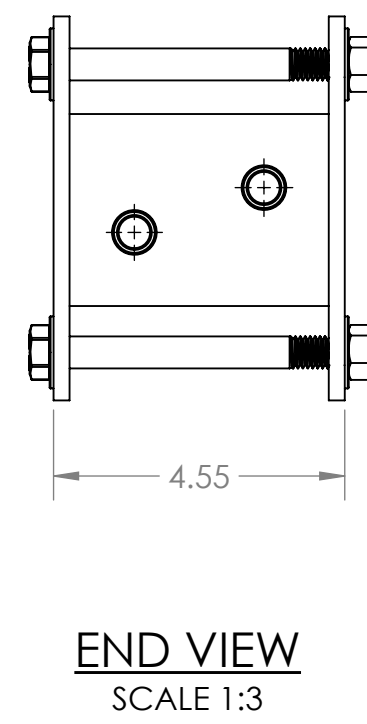
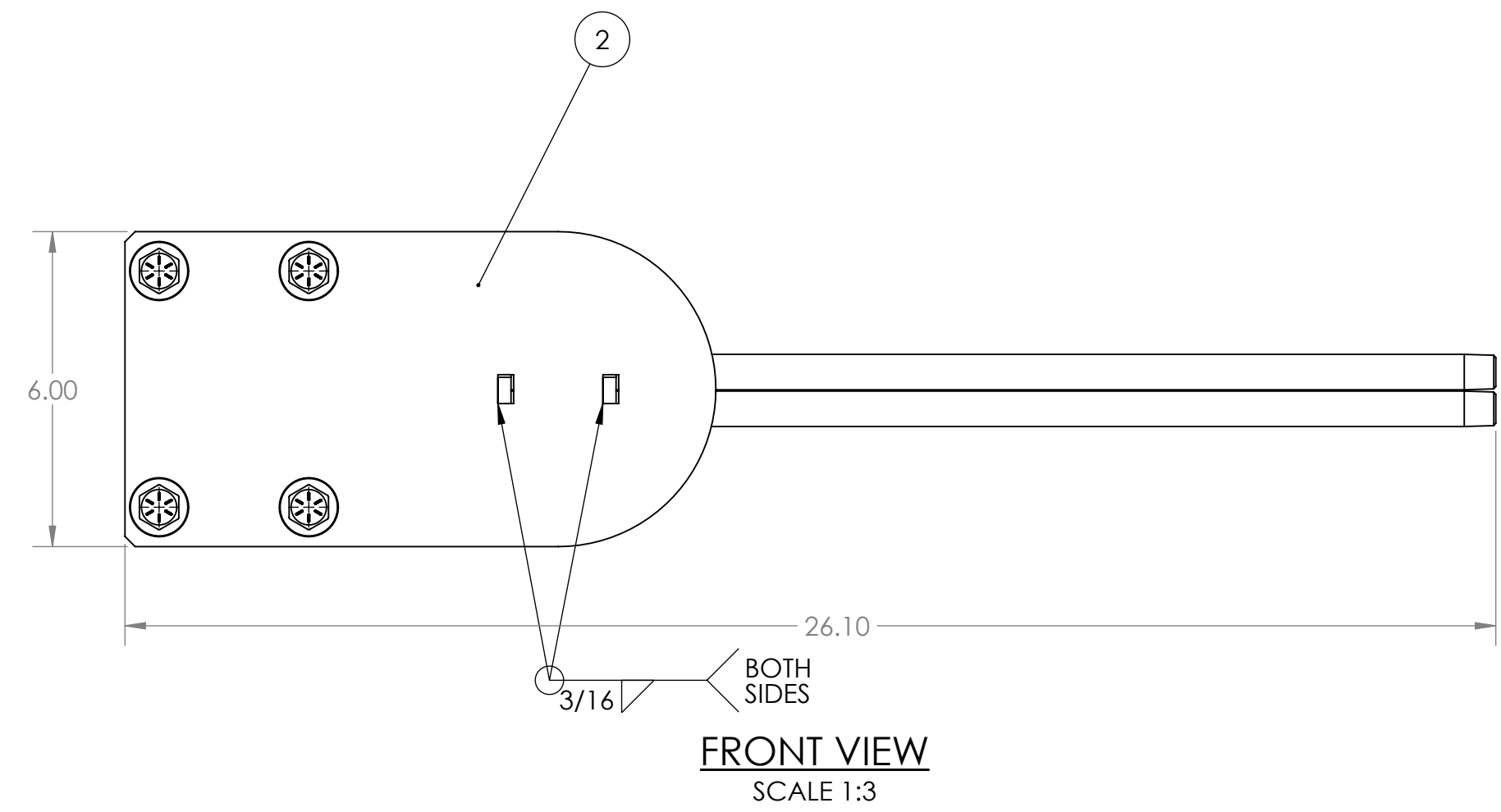
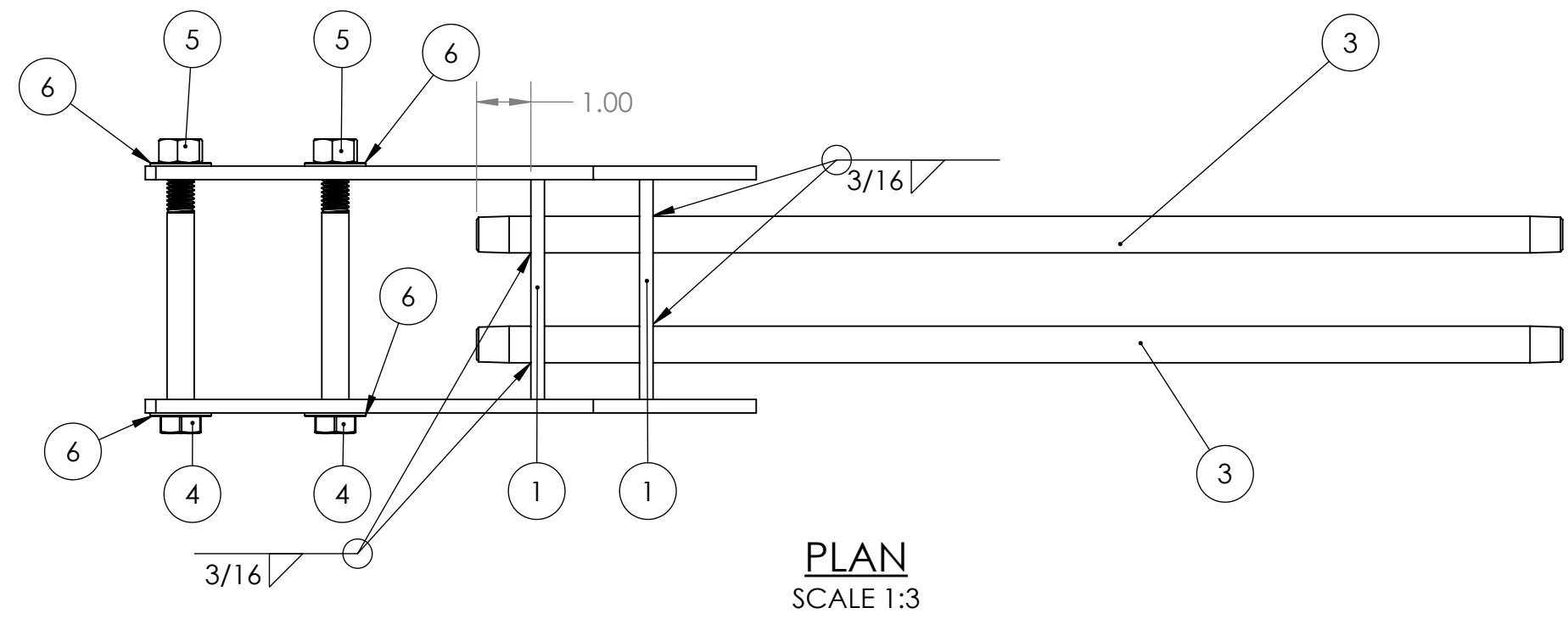

0	RELEASED FOR QUOTE	12/18/2025
		PJ
		DATE:
		APPROVED BY:
UNLESS OTHERWISE SPECIFIED: DIMENSIONS ARE IN FEET & INCHES		
DESIGNED	NP	09/01/2025
DRAWN	JF	10/31/2025
CHECKED	PJ	12/02/2025
APPROVED		

TITLE:
 CFM GEN 3.0
 ROLLER ASSEMBLY

SCALE: AS NOTED

PROJ. NO.	SIZE	SHEET NO.	REV
	D	011	0

CONFIDENTIAL INFORMATION: DO NOT DISTRIBUTE
 THE INFORMATION CONTAINED IN THIS DRAWING IS THE SOLE PROPERTY OF THE UNIVERSITY OF MAINE. ANY REPRODUCTION IN PART OR AS A WHOLE WITHOUT THE WRITTEN PERMISSION OF THE UNIVERSITY OF MAINE IS PROHIBITED.

NOTES:
 [2] GUIDE STOPS REQUIRED TOTAL.

BOM TABLE/ GUIDE STOP			
ITEM NO.	PART NUMBER	DESCRIPTION	QTY.
1	07_STOPPER PLATE	1/8" STEEL SHEET	1
2	07_STOPPER BLOCK	L2X2X 1/8	1
3	9541K31	THREADED-STUD BUMPER	1
4	95462A030	MEDIUM-STRENGTH STEEL HEX NUT	1
5	92141A030	18-8 STAINLESS STEEL WASHER	1
6	91268A261	HIGH-STRENGTH GRADE 8 STEEL HEX HEAD SCREW	2
7	92141A228	18-8 STAINLESS STEEL WASHER	2

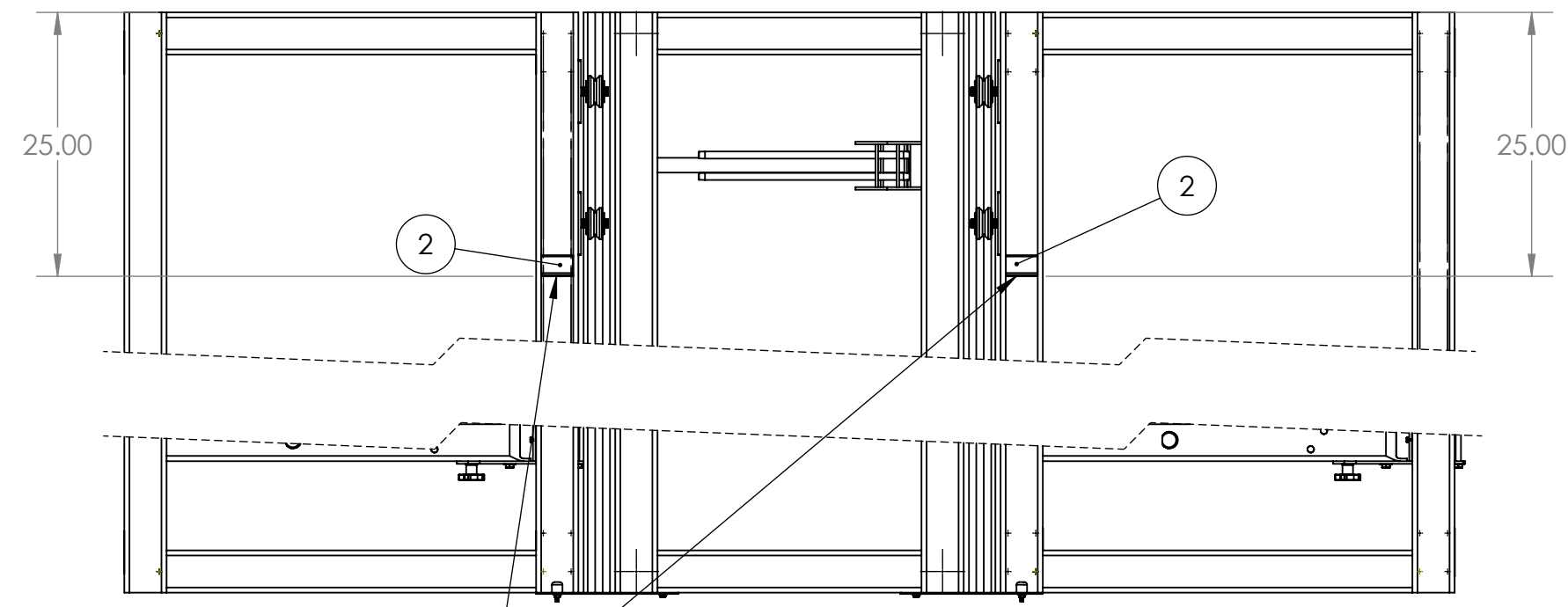

PLAN
 SCALE 1:16

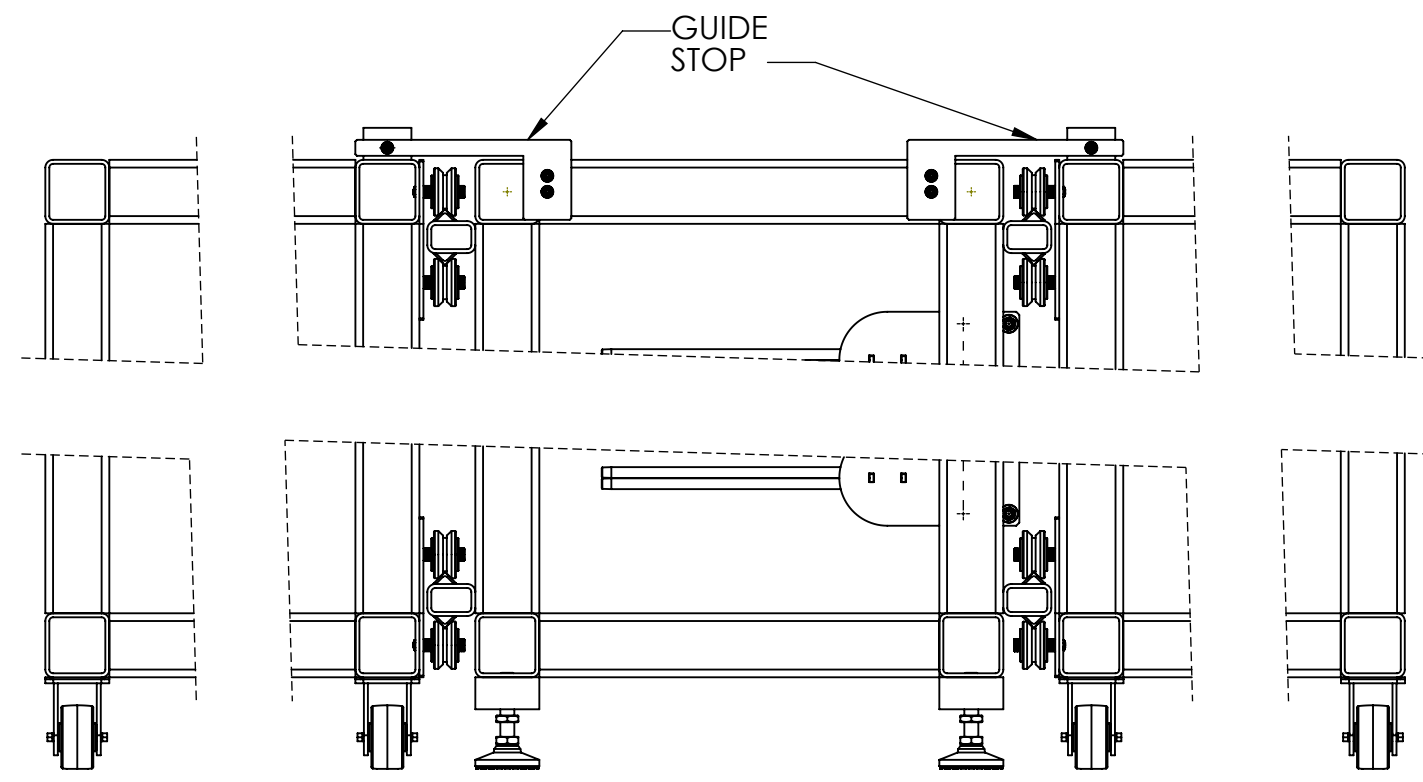

FULL ASSEMBLY
 FRONT VIEW
 SCALE 1:12

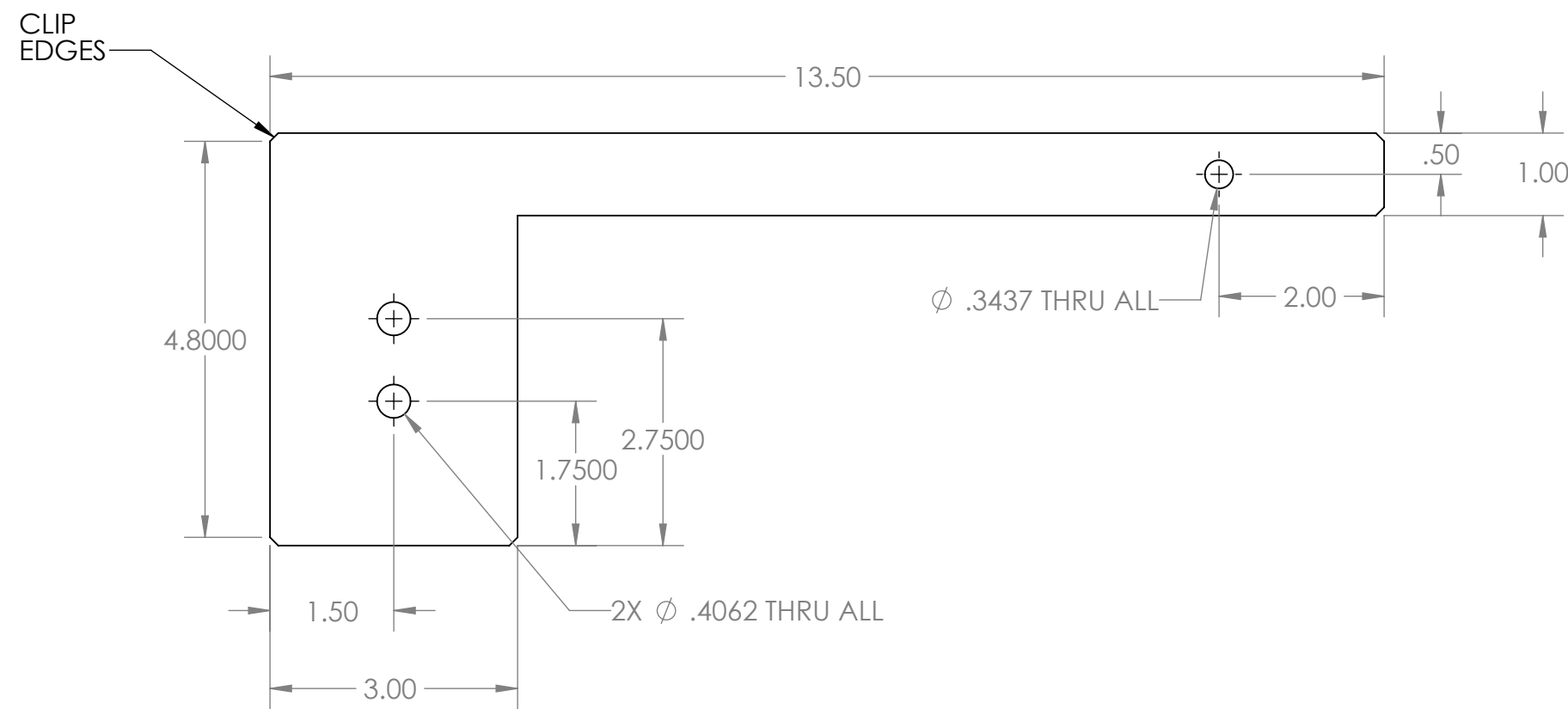

1 DETAIL
 SCALE 1:2

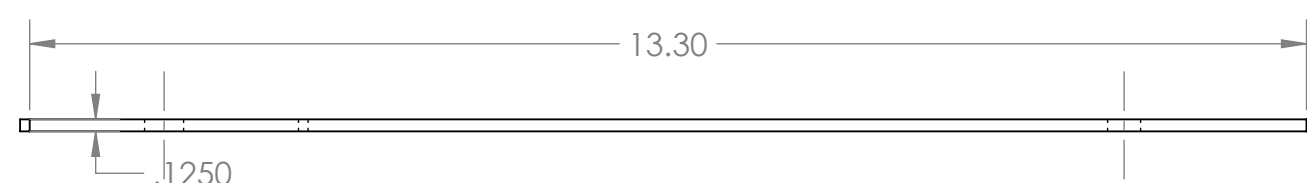

PLAN
 SCALE 1:2

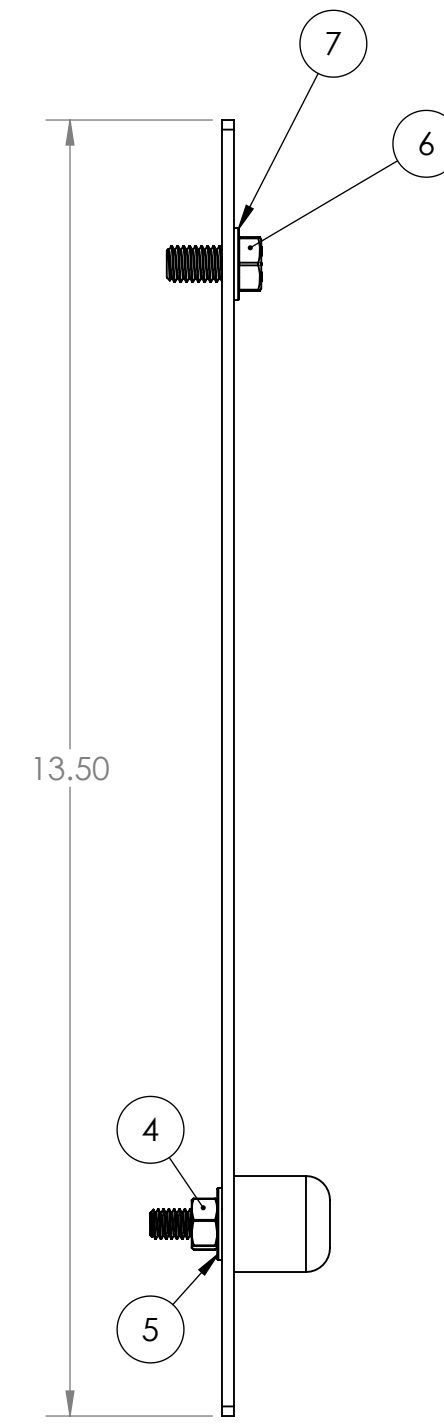

PLAN
 SCALE 1:2

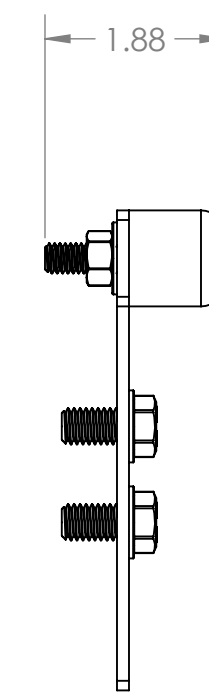

FRONT VIEW
 SCALE 1:2

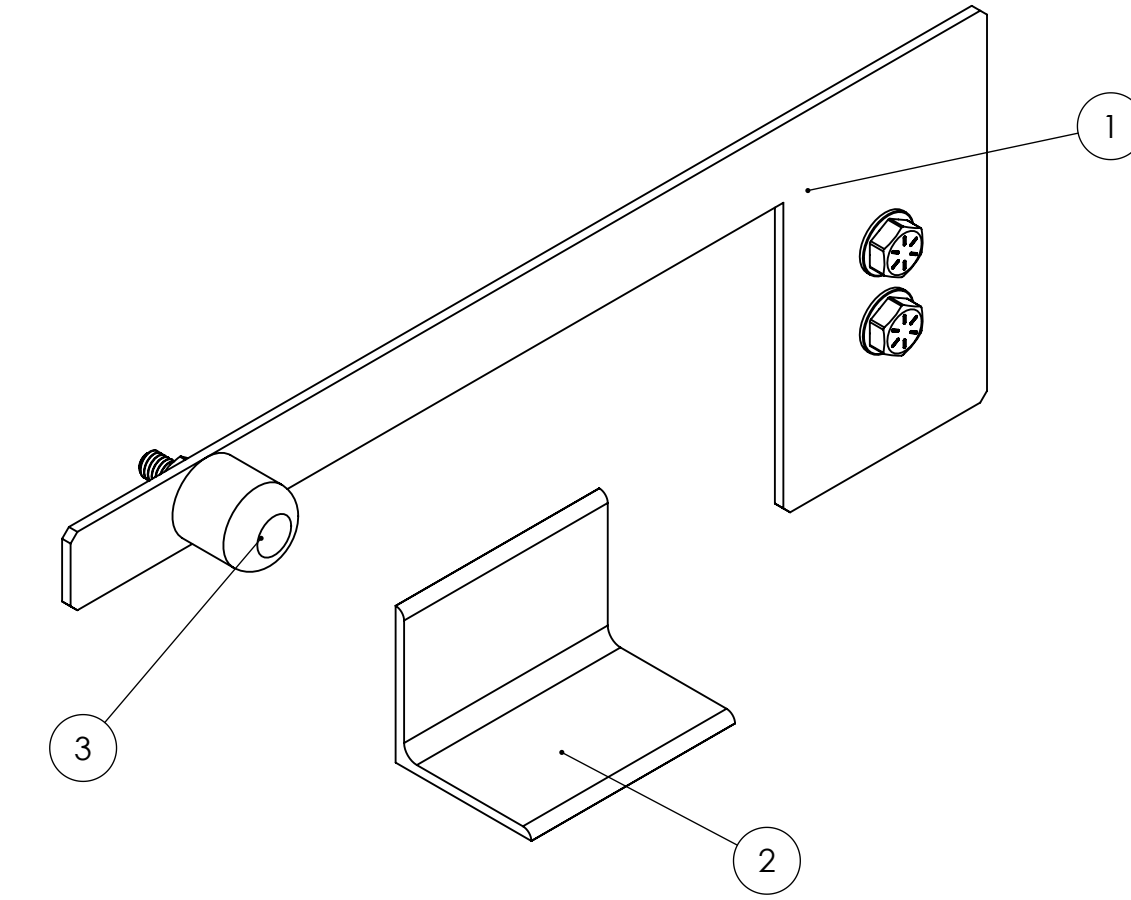

ISOMETRIC VIEW
 SCALE 1:2

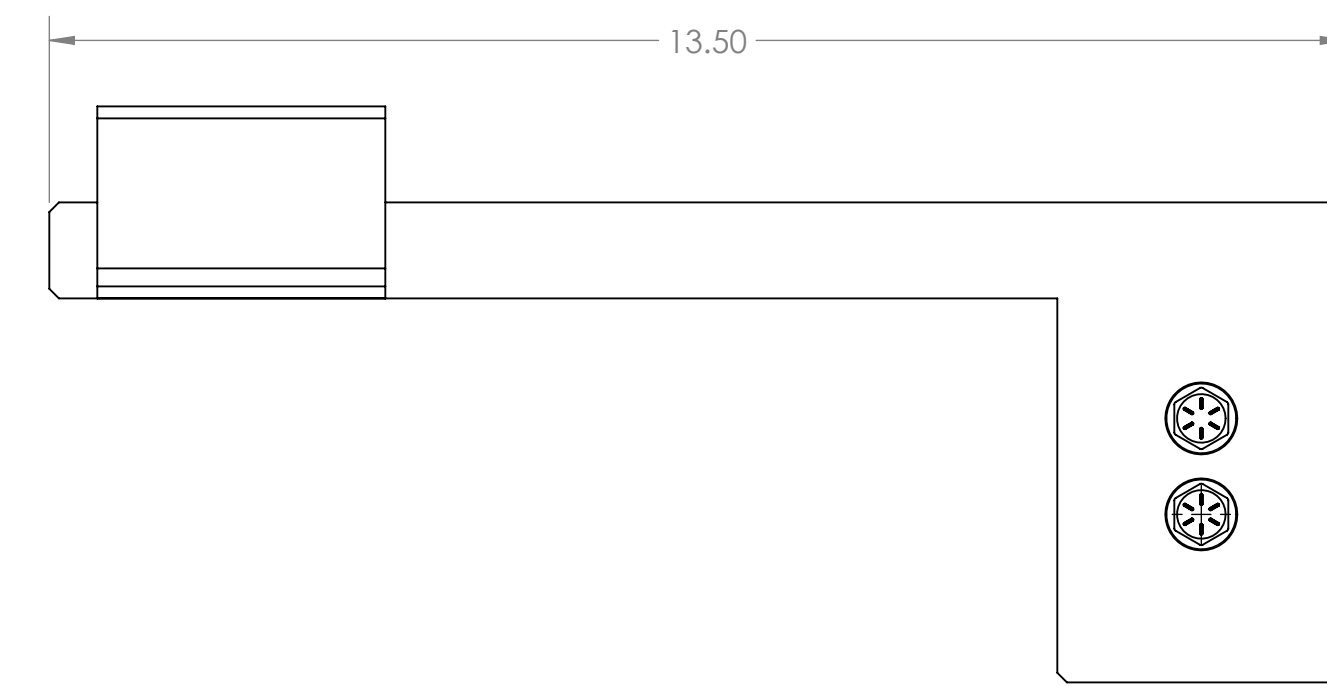

END VIEW
 SCALE 1:2

0	RELEASED FOR QUOTE	12/18/2025
		PJ
		DATE:
		APPROVED BY:
UNLESS OTHERWISE SPECIFIED: DIMENSIONS ARE IN FEET & INCHES		
DESIGNED	NP	09/01/2025
DRAWN	JF	10/31/2025
CHECKED	PJ	12/02/2025
APPROVED		

TITLE:
**CFM GEN 3.0
 GUIDE STOP**

SCALE: AS NOTED

PROJ. NO.

SIZE	SHEET NO.	REV
D	012	0