

Blackboard

# transaction *System*

*Copy Machine Reader  
Installation and Setup Guide*



Commerce Suite



Blackboard

# CONTENTS

## **1 COPY MACHINE READER INSTALLATION**

- 1 Overview
- 1 Reader Specifications

## **3 CR1120/CR1122 INSTALLATION**

- 3 Copier Interface
- 3 AC Electrical
- 3 Communications
- 4 Physical Mounting
- 5 Copier Connections for CR1120/CR1122 Readers**
- 5 Wiring Connections
- 6 Configuring the Reader Settings**
- 6 Removing the Reader Cover
- 8 DIP Switch Settings

## **9 CR2000/CR2002 READERS INSTALLATION**

- 9 Copier Interface
- 9 AC Electrical
- 10 Communications
- 10 Physical Mounting
- 11 Copier Connections for the CR2000/CR2002**
- 11 Wiring Connections
- 13 Configuring the Reader Settings**
- 13 Opening the Reader

## **16 XEROX COPIER CONNECTIONS FOR THE CR1120/CR1122**

- 16 Wiring Connections
- 17 Configuring the Reader Settings**
- 17 Removing the Reader Cover
- 19 DIP Switch Settings

## **20 XEROX COPIER CONNECTIONS FOR THE CR2002**

- 20 Wiring Connections

**21 Configuring the Reader Settings**

**23 XEROX COPIER CONNECTIONS FOR THE CR2000**

23 Wiring Connections

**24 Configuring the Reader Settings**

**26 MOUNTING STANDS**

26 Stand Materials

**27 Mounting Stand: CR2000/CR2002**

**28 Mounting Stand: CR1120/CR1122**

**29 Mounting Diagrams**

29 Mounting Diagram for CR1120/CR1122

30 Mounting Diagram for CR2000/CR2002

# COPY MACHINE READER INSTALLATION

## Overview

This manual provides general installation instructions for Blackboard's Copy Machine Readers CR1120, CR1122, CR2000, and CR2002. Instructions are included to set baud rate, address, loop, copier specifications and mounting diagrams.

## READER OVERVIEW

Blackboard's Copy Machine Reader is space-saving and easily mountable with a swipe style card slot. The rugged metal construction makes the reader tamper resistant and lets it withstand the abuse of high-traffic environments.

The CR1120/CR1122 Reader features a one-line by 24 character liquid crystal display.

The CR2000/2002 Reader with keypad features a two-line by 20 character vacuum fluorescent display. It also provides a 20-key keypad that allows account overrides or departmental charges.

Each reader is engraved with a diagram to help the user properly insert the magnetic-stripped card. An inactive time-out value, set through the *Optim9000* System software, indicates the amount of time a Copy Machine Reader remains active while a card is still inserted but no copies are being made.

Copy Machine Readers allows the *Optim9000* System control the use of a copy machine and to enter information at the time of the transaction.

---

*Copy Machine readers connecting to a Universal Edition Host require an IP Converter (IPC).*

---

## Reader Specifications

### READER COMMUNICATIONS

- Asynchronous, full duplex  
*Up to 9600 bits per second*
- RS-485 multidrop  
*4,000 feet per line; 16 readers per line*

## POWER

- CR1120/CR1122: Wall mount style transformer  
*Input: 120 VAC, 6 W*
- CR2000/CR2002: Voltage: 120 VAC single phase  
*Current: 1A*

## PHYSICAL CHARACTERISTICS

- CR1120/CR1122 Dimensions:  
*11.7 inches wide x 6 inches deep x 2.5 inches high*
- CR2000/CR2002 Dimensions:  
*7.1 inches wide x 7.5 inches deep x 4.4 inches high*

## ENVIRONMENTAL CHARACTERISTICS

- Operating:  
*Temperature: 0 to +60 degrees C*  
*Relative humidity: 0 to 95 percent non-condensing*  
*Altitude: 0 - 10,000 feet*
- Non-operating:  
*Temperature: -20 to +70 degrees C*  
*Altitude: 0 - 35,000 feet*

# CR1120/CR1122 INSTALLATION

CR1120/CR1122 reader installation is divided into four areas:

- **Copier Interface** (page 3)
- **AC Electrical** (page 3)
- **Communications** (page 3)
- **Physical Mounting** (page 4)

## Copier Interface

The CR1120/CR1122 has an interface cable that must be connected to the copier. Signals that enable the machine and count the number of copies made are carried in this cable. The cable is 11 feet long, with a connector near the copier end for ease of removing or replacing readers and copiers.

The installer must know where to connect the CR1120/CR1122 to the copy machine to receive these signals. The copier dealer or service provider must provide this information. We recommend the copier dealer or service provider install the interface cable to avoid any machine warranty or service agreement issues which may arise.

---

*A trained electronic technician should complete all wiring. The interface cable has a pigtail on the copy machine end. It is the responsibility of the installer to provide the correct connector or splices to attach to the machine.*

---

## AC Electrical

Every CR1120/CR1122 requires an 120 VAC (5–15R) receptacle for the AC adaptor. The cable length between the AC adaptor and the reader is five feet.

## Communications

Communications to the *Optim9000* System host is accomplished through the *Optim9000* reader network. The CR1120/CR1122 is shipped with a 10-foot cable terminated with an RJ-45 connector. The reader

address and baud rate are set via DIP switches inside the CR1120/CR1122. See [Configuring the Reader Settings](#) (page 13) for instructions on how to set the baud rate and address.

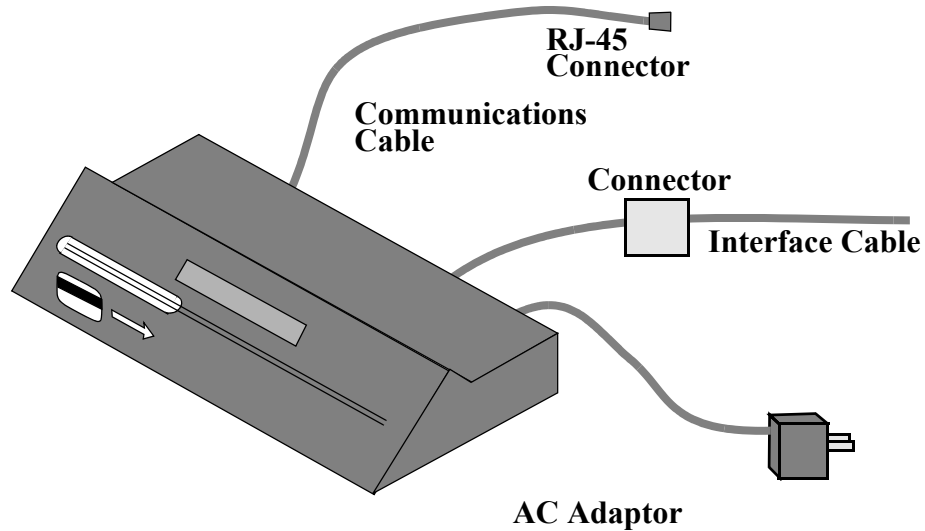

### Physical Mounting

The mounting location for the CR1120/CR1122 should not interfere with operating or servicing the copier. Patrons who use the CR1120/CR1122 must be able to see the display and insert their cards easily. Two threaded mounting holes on the bottom are provided to secure the CR1120/CR1122 to a shelf or mounting stand.

---

*Ensure that mounting screws do not penetrate more than 1/2" into the unit or damage to the circuit board may result.*

---

For CR1120/CR1122 mounting dimensions, see ([Mounting Stand: CR1120/CR1122](#) (page 28)).

## COPIER CONNECTIONS FOR CR1120/CR1122 READERS

This section explains the connections and DIP switches settings for most copy machines. Xerox copiers require a different approach, as described in [Xerox Copier Connections for the CR1120/CR1122](#) (page 16).

### Wiring Connections

#### CONNECTING THE WIRE HARNESS

The copy machine must be designed to be enabled by a connection of two wires or terminals. The CR1120 enables the machine by a dry contact relay closure. The CR1122 enables the machine by a dry contact closure or an open relay contact. The green and white wires are for a machine that requires a contact closure to enable the machine. The green and brown wires are for a machine that requires a contact closure to disable the machine.

GREEN– Relay common (C) contact

WHITE– Relay normally open (NO) contact

BROWN – Relay normally closed (NC) contact (Available on CR1122 only)

The copy machine must have a signal that is used to indicate that a copy has been made. This can be a +24V pulse, +5V pulse, a ground pulse, or a relay contact pulse.

Pulse Type	Wire Connection
+24V pulse	RED – Connect to +24V pulse signal of copy machine <sup>1</sup> BLACK – Connect to logic ground of copy machine
+5V pulse	RED – Connect to +5V pulse signal of copy machine BLACK – Connect to logic ground of copy machine
+Ground pulse	RED – Connect to +5V or +24VDC supply in copy machine BLACK – Connect to ground pulse signal of copy machine
Relay contact pulse	RED – Connect to relay (sourced by CR1120/CR1122 +9V) BLACK – Connect to relay (to opto in CR1120/CR1122)

1. Observe polarity or the count pulse may be invalid.



Set DIP switches for the correct input pulse, as described later in this section.

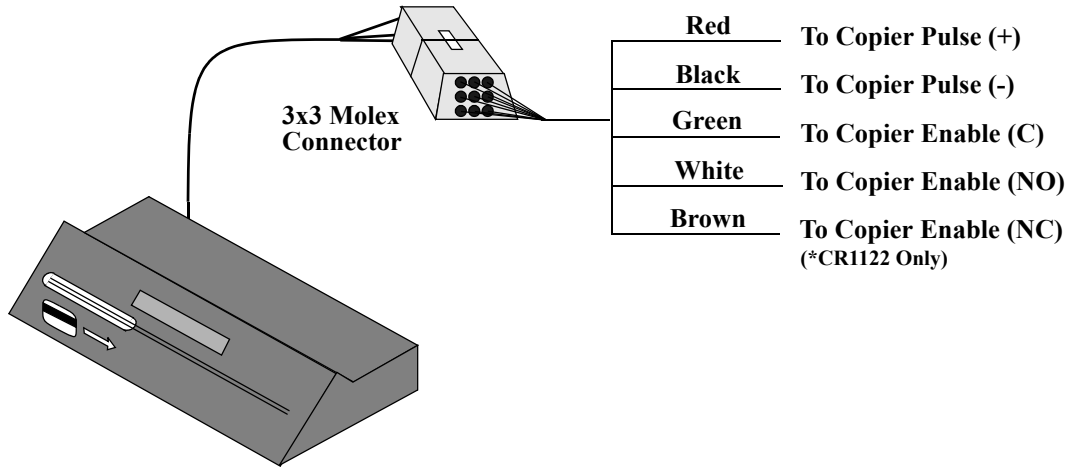

## CONFIGURING THE READER SETTINGS

The circuit board inside the CR1120/CR1122 has two banks of DIP switches. DIP switch S1 configures the type of copy machine interface. DIP switch S2 configures the reader address and baud rate. DIP switch S3 is preset at the factory for a +24VDC pulse interface. To access the DIP switches, remove the top cover.

### Removing the Reader Cover

To open the reader, follow these steps:

- 1 Remove the four tamper screws to loosen the cover piece.
- 2 Lift the cover from the reader.

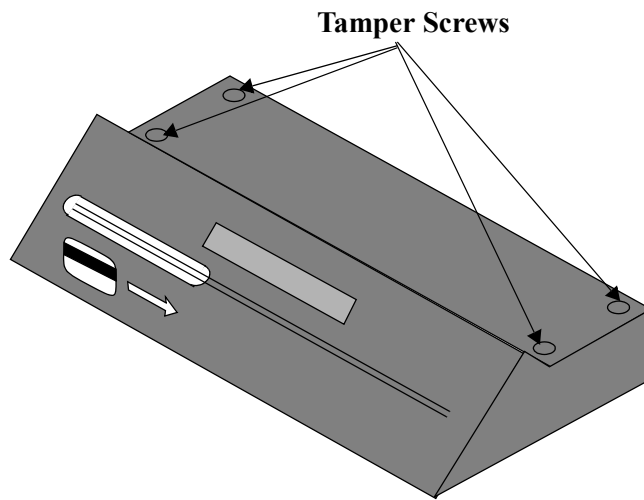



---

*There is a chart on the bottom of the cover that indicates the DIP switch settings and their functions.*

---

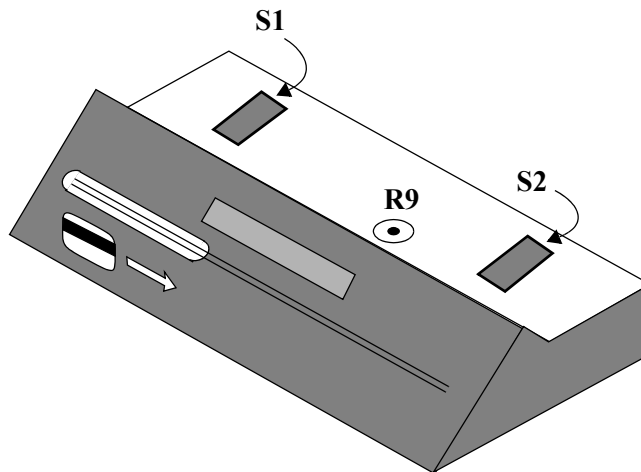
- 3 Set the DIP switches according to the chart inside the reader cover, or use the tables on the next page.



- 4 Plug in the CR1120/CR1122 with the cover removed and set the display's viewing angle by turning R9 with a non-conductive screwdriver.
- 5 Replace cover and reattach it with the tamper screws.

**DIP Switch Settings**

Switch 1 settings based on the interface type are

Position:	1	2	3	4	5	6	7	8
+5V Pulse	Off	Off	Off	ON	Off	Off	ON	Off
+24V Pulse	Off	Off	Off	ON	Off	ON	Off	Off
Dry Contact	Off	ON	ON	Off	ON	Off	Off	Off

Switch 2 settings based on net type, baud rate, and address are:

Position:	1	2	3	4	5	6	7	8
Standard Net Type	Off							
Remote Net Type	ON							
1200 Baud		Off	Off	Off				
2400 Baud		Off	Off	Off				
4800 Baud		Off	ON	Off				
9600 Baud		Off	ON	ON				
Address 0					Off	Off	Off	Off
Address 1					Off	Off	Off	ON
Address 2					Off	Off	ON	Off
Address 3					Off	Off	ON	ON
Address 4					Off	ON	Off	Off
Address 5					Off	ON	Off	ON
Address 6					Off	ON	ON	Off
Address 7					Off	ON	ON	ON
Address 8					ON	Off	Off	Off
Address 9					ON	Off	Off	ON
Address 10					ON	Off	ON	Off
Address 11					ON	Off	ON	ON
Address 12					ON	ON	Off	Off
Address 13					ON	ON	Off	ON
Address 14					ON	ON	ON	Off
Address 15					ON	ON	ON	ON

## CR2000/CR2002 READERS INSTALLATION

CR2000/CR2002 Copy Machine Reader installation is divided into four areas:

- **Copier Interface** (page 9)
- **AC Electrical** (page 9)
- **Communications** (page 10)
- **Physical Mounting** (page 10)

### Copier Interface

The CR2000/CR2002 has an interface cable that must be connected to the copier. Signals that enable the machine and count the number of copies made are carried in this cable. The cable is 11 feet long, with a connector near the copier end for ease of removing or replacing readers and copiers. Required signals are listed in the “Copier Connections for the CR2000/CR2002” section. Required signals for Xerox Copy machines are listed in the “Xerox Copier Connections for the CR2000” or “Xerox Copier Connections for the CR2002” section.

The installer must know where to connect the CR2000/CR2002 to the copy machine to receive these signals. The copier dealer or service provider must provide this information. We recommend the copier dealer or service provider install the interface cable to avoid any machine warranty or service agreement issues which may arise.

---

*A trained electronic technician should complete all wiring. The interface cable has a pigtail on the copy machine end. It is the responsibility of the installer to provide the correct connector or splices to attach to the machine.*

---

### AC Electrical

Every CR2000/CR2002 requires an 110VAC (5–15R) receptacle for the AC adaptor. The AC adaptor box has two cables: one to the wall receptacle (three feet), and the other to the reader (five feet).

**Communications**

Communications to the *Optim9000* System host is accomplished through the *Optim9000* reader network. The CR2000/CR2002 ships with a 10-foot cable terminated with an RJ-45 connector.

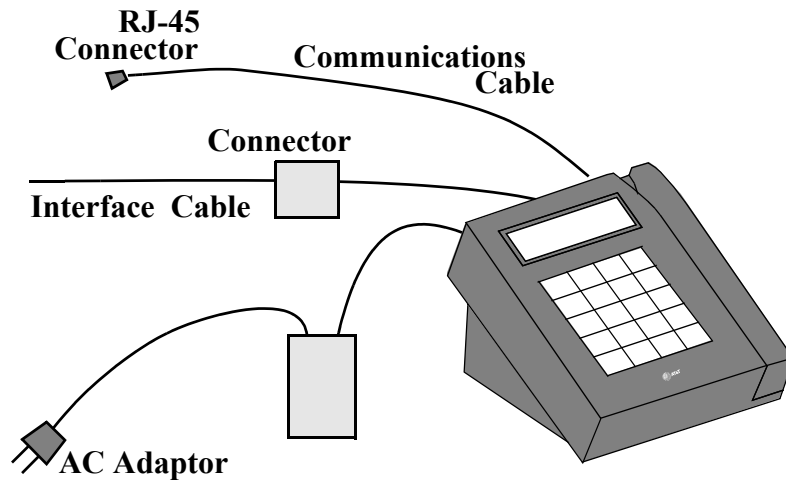

**Physical Mounting**

The mounting location for the CR2000/CR2002 must not interfere with operating or servicing the copier. Patrons who use the CR2000/CR2002 must be able to see the display and insert the card from the top of the card slot. Two threaded mounting holes on the bottom are provided to secure the CR2000/CR2002 to a shelf or mounting stand. For CR2000/CR2002 mounting dimensions, see [Mounting Stands](#) (page 26) and example mounting stands are included in this manual.

## COPIER CONNECTIONS FOR THE CR2000/CR2002

This section explains the connection and DIP switch settings for most copy machine readers. Xerox copiers require a different approach which is described in [Xerox Copier Connections for the CR2000](#) (page 23), or see [Xerox Copier Connections for the CR2002](#) (page 20) for CR2002 readers.

### Wiring Connections

#### CONNECTING THE WIRE HARNESS

The copy machine is designed to be enabled by a connection of two wires or terminals. The CR2000/CR2002 enables the machine by a dry contact closure of a relay:

- BROWN - Relay common (C) contact
- RED - Relay normally open (NO) contact
- BLACK - Relay normally closed (NC) contact (CR2002 only)

The copy machine must have a signal that indicates a copy was made. This can be a +24V pulse, +5V pulse, a ground pulse, or a relay contact pulse.

Pulse Type	Wire Connection
+24V pulse	GREEN – Connect to +24V pulse signal of copy machine BLUE – Connect to logic ground of copy machine
+5V pulse	GREEN – Connect to +5V pulse signal of copy machine BLUE – Connect to logic ground of copy machine
+Ground pulse	GREEN – Connect to +5V or +24VDC supply in copy machine BLUE – Connect to ground pulse signal of copy machine
Relay contact pulse	GREEN – Connect to relay (sourced by CR2000 +24V) BLUE – Connect to relay (to opto in CR2000)

Be sure to set DIP switches for the correct input pulse, as described later in this section.

# COPIER CONNECTIONS FOR THE CR2000/CR2002

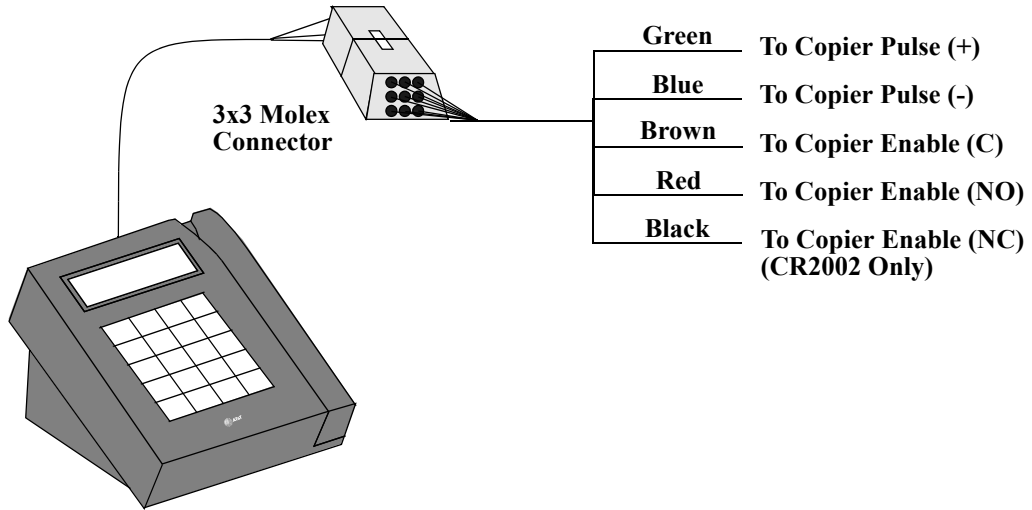

## CONFIGURING THE READER SETTINGS

The interface board inside the CR2000/CR2002 has two banks of DIP switches for configuring the type of copy machine interface. It is preset at the factory for a +24VDC pulse interface (or ground pulse using +24VDC supply). The DIP switches are on the board attached to the inside of the bottom cover. The installer must open the reader to access them.

### Opening the Reader

To open the reader, follow these steps:

- 1 Place the reader upside down on a non-abrasive surface.
- 2 Remove the 10 tamper screws that hold the base to the face plate.
- 3 Carefully lift the bottom of the reader as illustrated below. Do not pull on the ribbon cable that connects the base to the face plate.

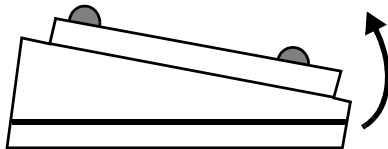

**Lift at the narrow end, using  
the wide end as a pivot.**

---

*The DIP switches can be accessed once the reader is open. They are located in the base near the ribbon cable that connects the two halves of the reader together.*

---



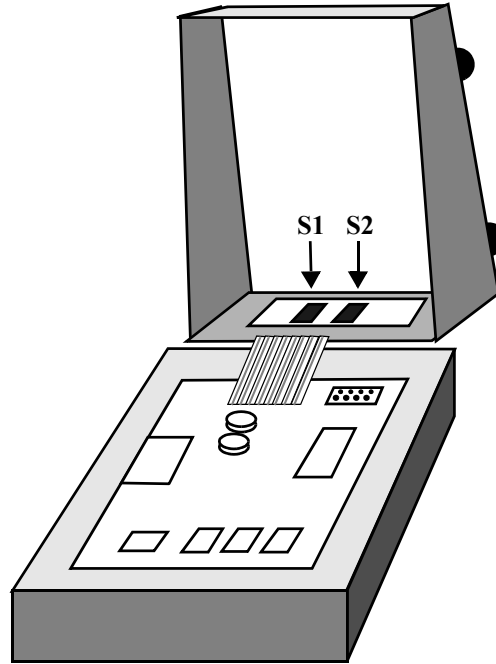

The DIP switch assembly area is as shown in this diagram.

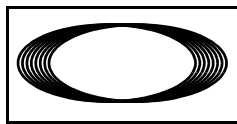

Relay

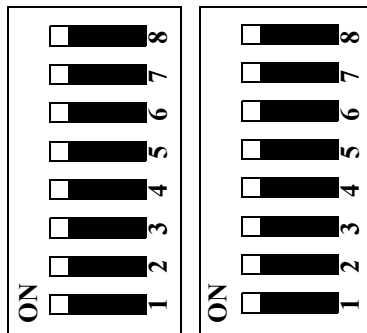

S1

S2

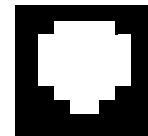

RJ-12 Jack

- Follow the guidelines in the table below to set DIP switches for the CR2000/CR2002.

Pulse Type	Switch	1	2	3	4	5	6	7	8
+24VDC pulse <sup>1</sup>	S1	Off	Off	Off	ON	Off	ON	Off	Off
	S2	Off	Off	Off	Off	Off	Off	Off	Off

Pulse Type	Switch	1	2	3	4	5	6	7	8
+5VDC pulse <sup>2</sup>	S1	Off	Off	Off	<b>ON</b>	Off	Off	<b>ON</b>	Off
	S2	Off	Off	Off	Off	Off	Off	Off	Off
Relay contact pulse	S1	Off	Off	<b>ON</b>	Off	<b>ON</b>	Off	Off	<b>ON</b>
	S2	Off	Off	Off	Off	Off	Off	Off	Off

1. Or ground pulse using +24VDC supply.
- 2.Or ground pulse using +5VDC supply.

5 Adjust DIP switches and reassemble.

## XEROX COPIER CONNECTIONS FOR THE CR1120/ CR1122

This section explains the connection and DIP switch settings for Xerox copiers. All Xerox copiers with a DB15 foreign device interface are supported using the supplied Xerox adapter cable. Refer to [Copier Connections for CR1120/CR1122 Readers](#) (page 5) or contact Blackboard Technical Services if the Xerox machine does not have a DB15 interface connector.

### Wiring Connections

#### CONNECTING THE WIRE HARNESS

Use the Xerox adapter cable (P/N 044-042-030) in place of the pigtail adapter to connect to the machine.

The information below is for reference only.

Wire Color	Connection
Red	To Xerox DB-15 interface connector pin #8 Copy count +
Black	To Xerox DB-15 interface connector pin #9 Copy count -
Green	To Xerox DB-15 interface connector pin #1 Copier enable
White	To Xerox DB-15 interface connector pin #3 Copier enable

---

*Be sure to set DIP switches for the correct input pulse.*

---

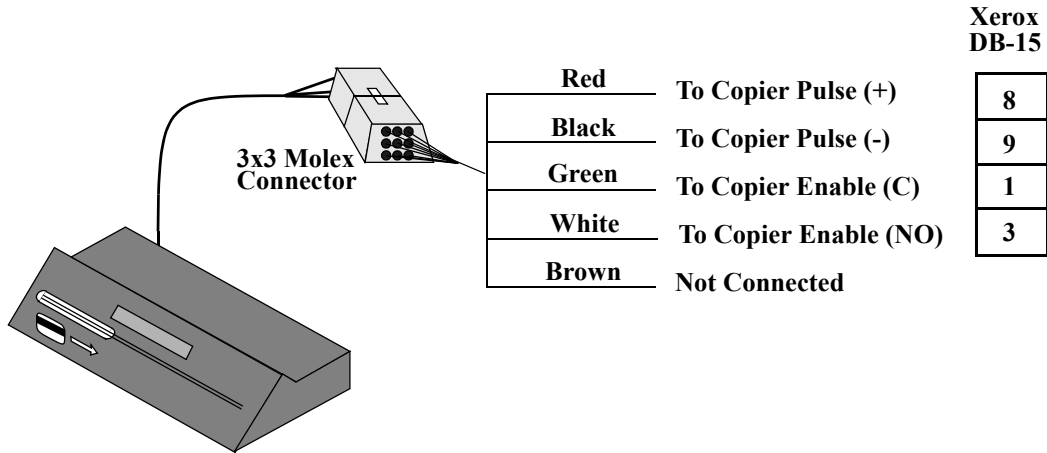

## CONFIGURING THE READER SETTINGS

The circuit board inside the CR1120/CR1122 has two banks of DIP switches. DIP switch S1 configures the type of copy machine interface. DIP switch S2 configures the reader address and baud rate.

To access the DIP switches, remove the top cover.

### Removing the Reader Cover

To open the reader, follow these steps:

- 1 Remove the four tamper screws to loosen the cover piece.
- 2 Lift the cover from the reader.

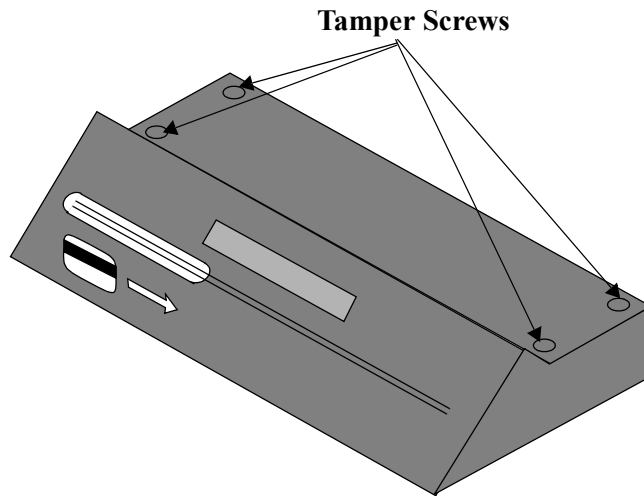

There is a chart on the bottom of the cover that indicates the DIP switch settings and their functions.

- 3 Set the DIP switches according to the tables below.

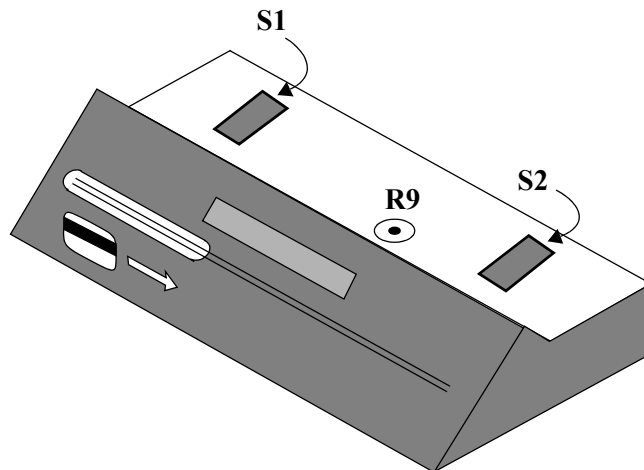

- 4 Plug in the CR1120/CR1122 with the cover removed and set the display's viewing angle by turning R9 with a non-conductive screwdriver.

- 5 Replace cover and reattach it with the tamper screws.

**DIP Switch Settings**

Switch 1 settings are:

1	2	3	4	5	6	7	8
Off	ON	ON	Off	ON	Off	Off	Off

Switch 2 settings based on net type, baud rate, and address are:

Position:	1	2	3	4	5	6	7	8
Standard Net Type	Off							
Remote Net Type	ON							
1200 Baud		Off	Off	Off				
2400 Baud		Off	Off	Off				
4800 Baud		Off	ON	Off				
9600 Baud		Off	ON	ON				
Address 0					Off	Off	Off	Off
Address 1					Off	Off	Off	ON
Address 2					Off	Off	ON	Off
Address 3					Off	Off	ON	ON
Address 4					Off	ON	Off	Off
Address 5					Off	ON	Off	ON
Address 6					Off	ON	ON	Off
Address 7					Off	ON	ON	ON
Address 8					ON	Off	Off	Off
Address 9					ON	Off	Off	ON
Address 10					ON	Off	ON	Off
Address 11					ON	Off	ON	ON
Address 12					ON	ON	Off	Off
Address 13					ON	ON	Off	ON
Address 14					ON	ON	ON	Off
Address 15					ON	ON	ON	ON

# XEROX COPIER CONNECTIONS FOR THE CR2002

This section explains the connections and DIP switches settings for Xerox copiers. All Xerox copiers with a DB15 foreign device interface are supported using the supplied Xerox adapter cable. Refer to [Copier Connections for the CR2000/CR2002](#) (page 11) or contact Blackboard Technical Services if the Xerox machine does not have a DB15 interface connector.

## Wiring Connections

### CONNECTING THE WIRE HARNESS

Use the Xerox adapter cable (P/N 044-042-030) in place of the pigtail adapter to connect to the machine.

The information below is for reference only.

Wire Color	Connection
Blue	To Xerox DB-15 interface connector pin #8 Copy count +
Gray	To Xerox DB-15 interface connector pin #9 Copy count -
Red	To Xerox DB-15 interface connector pin #1 Copier enable
Brown	To Xerox DB-15 interface connector pin #3 Copier enable

Set DIP switches for the correct input pulse, as described later in this section.

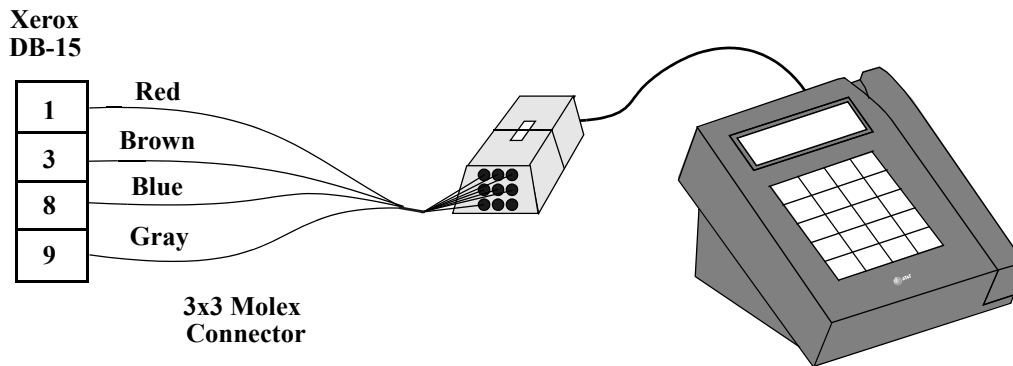

## CONFIGURING THE READER SETTINGS

The interface board inside the CR2002 has two banks of DIP switches for configuring the copy machine interface. It is preset at the factory for a +24VDC pulse interface (or ground pulse using +24VDC supply). The DIP switches are on the board attached to the inside of the bottom cover. The reader must be opened to access the DIP switches.

To open the reader:

- 1 Place reader upside down on a non-abrasive surface.
- 2 Remove the ten tamper screws that hold the base to the face plate.
- 3 Carefully lift as illustrated below. Do not pull on the ribbon cable that connects the base to the face plate.

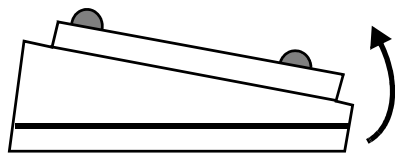

**Lift at the narrow end, using the wide end as a pivot.**

DIP switches are in the base near the ribbon cable that connects the two halves. The DIP switches can be accessed when the reader is open.

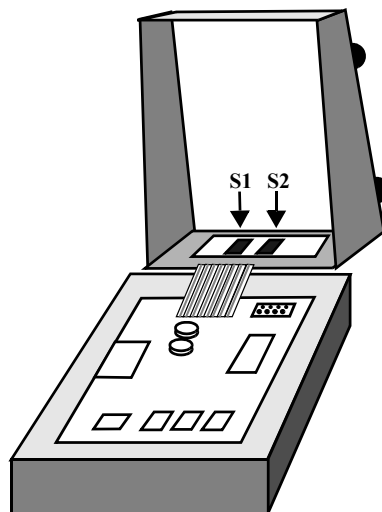



The DIP switch assembly area is as shown in this diagram.

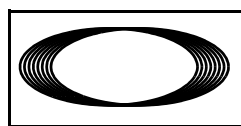

Relay



S1

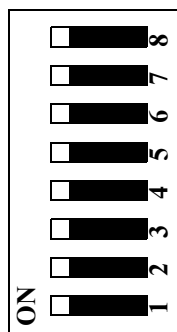

S2



RJ-12 Jack

4 Follow the guidelines in the table below to set the DIP switches.

Switch	1	2	3	4	5	6	7	8
S1	Off	ON	ON	Off	ON	Off	Off	Off
S2	Off	Off	Off	Off	ON	Off	Off	Off

## XEROX COPIER CONNECTIONS FOR THE CR2000

This section explains the connection and DIP switches settings for Xerox copiers. All Xerox copiers with a DB15 foreign device interface are supported. Refer to the General Copier Connections for the CR2000 or contact Blackboard Technical Services if the Xerox machine does not have a DB15 interface connector.

### Wiring Connections

#### CONNECTING THE WIRE HARNESS

Use these guidelines to connect the colored wires to the interface connector.

Wire Color	Connection
Blue	To Xerox DB-15 interface connector pin #8 Copy count +
Gray	To Xerox DB-15 interface connector pin #9 Copy count -
Red	To Xerox DB-15 interface connector pin #1 Copier enable
Brown	To Xerox DB-15 interface connector pin #3 Copier enable
Violet	To green wire
Green	To violet wire

Set DIP switches for the correct input pulse, as described later in this section.

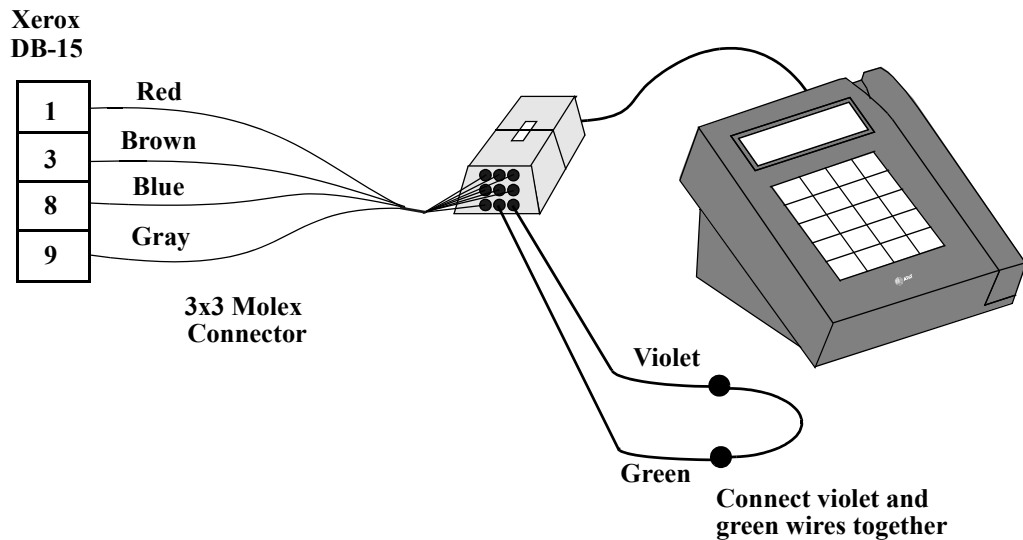

---

*The interface cable has a pigtail on the copy machine end. It is the responsibility of the installer to provide the correct connector or splices to attach to the machine.*

---

## CONFIGURING THE READER SETTINGS

The interface board inside the CR2000 has two banks of DIP switches for configuring the copy machine interface. It is preset at the factory for a +24VDC pulse interface (or ground pulse using +24VDC supply). The DIP switches are on the board attached to the inside of the bottom cover. The DIP switches can be accessed when the reader is open.

To open the reader:

- 1 Place reader upside down on a non-abrasive surface.
- 2 Remove the ten tamper screws that hold the base to the face plate.
- 3 Carefully lift as illustrated below. Do not pull on the ribbon cable that connects the base to the face plate.

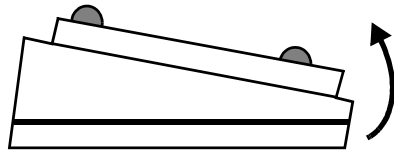

Lift at the narrow end, using the wide end as a pivot.

DIP switches are in the base near the ribbon cable that connects the two halves. The DIP switches can be accessed when the reader is open.

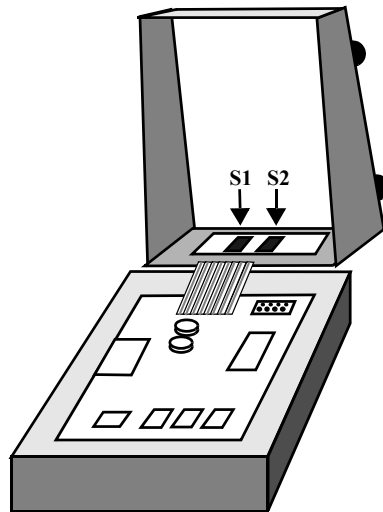

The DIP switch assembly area is as shown in this diagram.

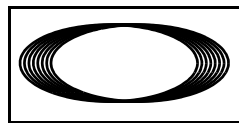

Relay

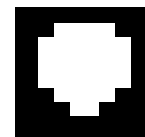
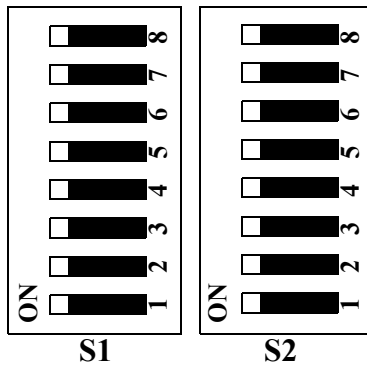

RJ-12 Jack

4 Follow the guidelines in the table below to set the DIP switches.

Switch	1	2	3	4	5	6	7	8
S1	Off	Off	Off	ON	Off	ON	Off	Off
S2	Off	Off	ON	Off	Off	ON	Off	ON

## MOUNTING STANDS

The CR1120/CR1122 or the CR2000/CR2002 Copy Machine Readers can be mounted on a separate stand to avoid drilling holes in the copy machine. This stand can be created by using the materials and construction shown on the next pages.

### Stand Materials

---

*Parts for either stand must be welded together.*

---

#### CR1120/CR1122 STAND MATERIALS

Material needed to create the stand for the CR1120/CR1122:

- 2 - 1/8" thick Steel Plates:
  - 1 - 8 1/2" x 12" Steel Plate
  - 1 - 11 3/4" x 6" Steel Plate
- 1- 3-foot Length of Steel Tubing (1 1/2 Outside Diameter)

#### CR2000/CR2002 STAND MATERIALS

Material needed to create the stand for the CR2000/CR2002:

- 2 - 1/8" thick Steel Plates:
  - 1 - 8 1/2" x 12" Steel Plate
  - 1 - 6" x 6" Steel Plate
- 1- 3-foot Length of Steel Tubing (1-1/2 Outside Diameter)

MOUNTING STAND: CR2000/CR2002

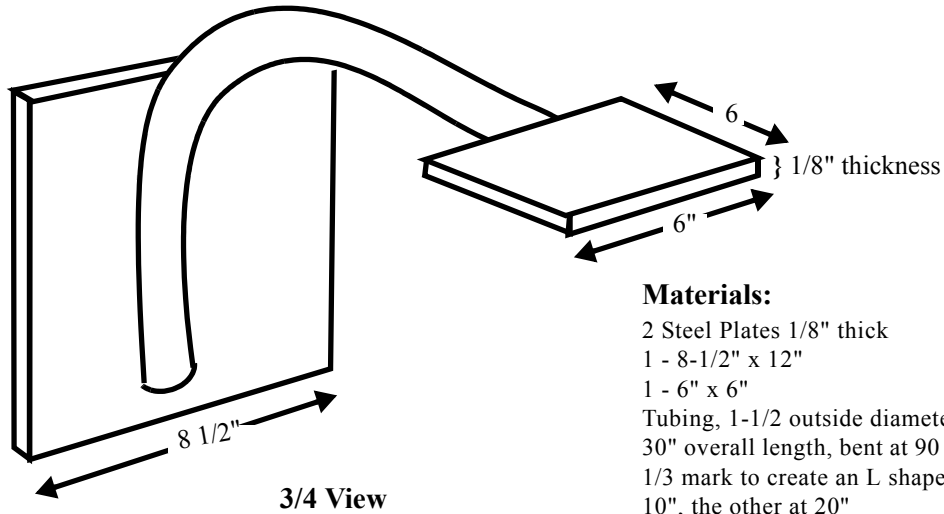

**Materials:**

- 2 Steel Plates 1/8" thick
- 1 - 8-1/2" x 12"
- 1 - 6" x 6"
- Tubing, 1-1/2" outside diameter
- 30" overall length, bent at 90 degree angle at the 1/3 mark to create an L shape, with one leg at 10", the other at 20"
- The tube is welded to the center lines of the steel plates
- All materials should be painted flat black.

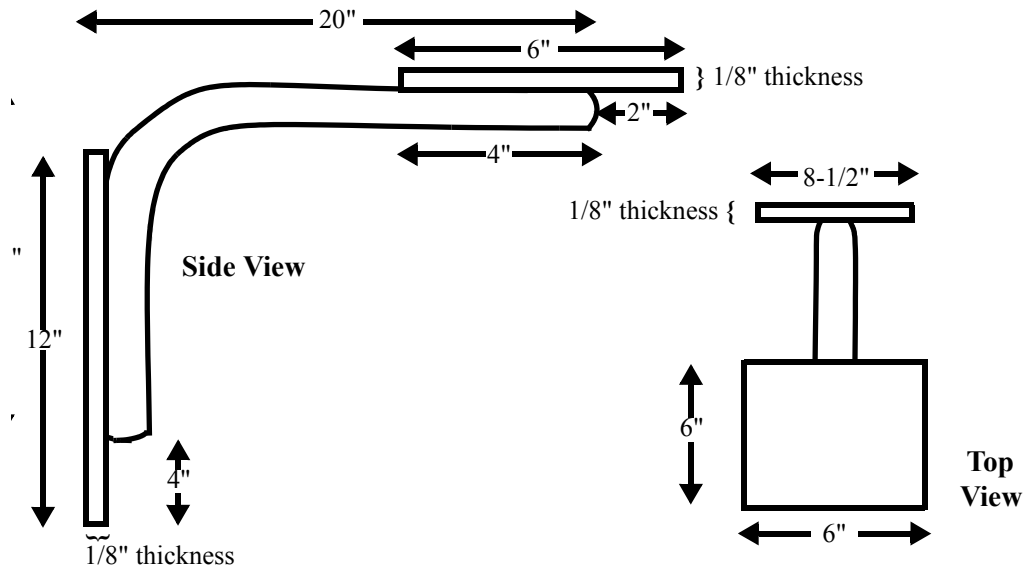

MOUNTING STAND: CR1120/CR1122

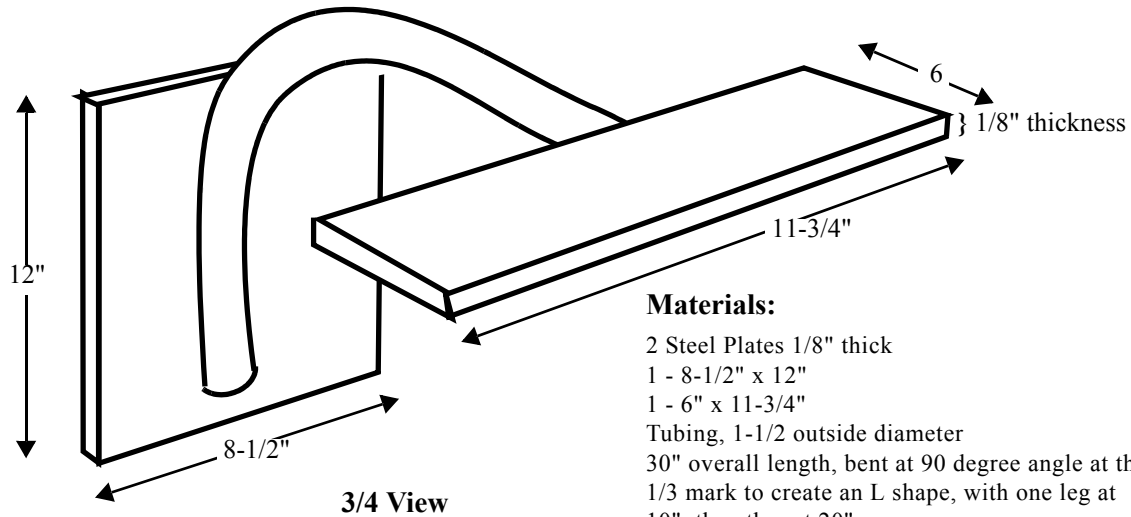

**Materials:**

- 2 Steel Plates 1/8" thick
- 1 - 8-1/2" x 12"
- 1 - 6" x 11-3/4"
- Tubing, 1-1/2" outside diameter
- 30" overall length, bent at 90 degree angle at the 1/3 mark to create an L shape, with one leg at 10", the other at 20"
- The tube is welded to the center lines of the steel plates
- All materials should be painted flat black.

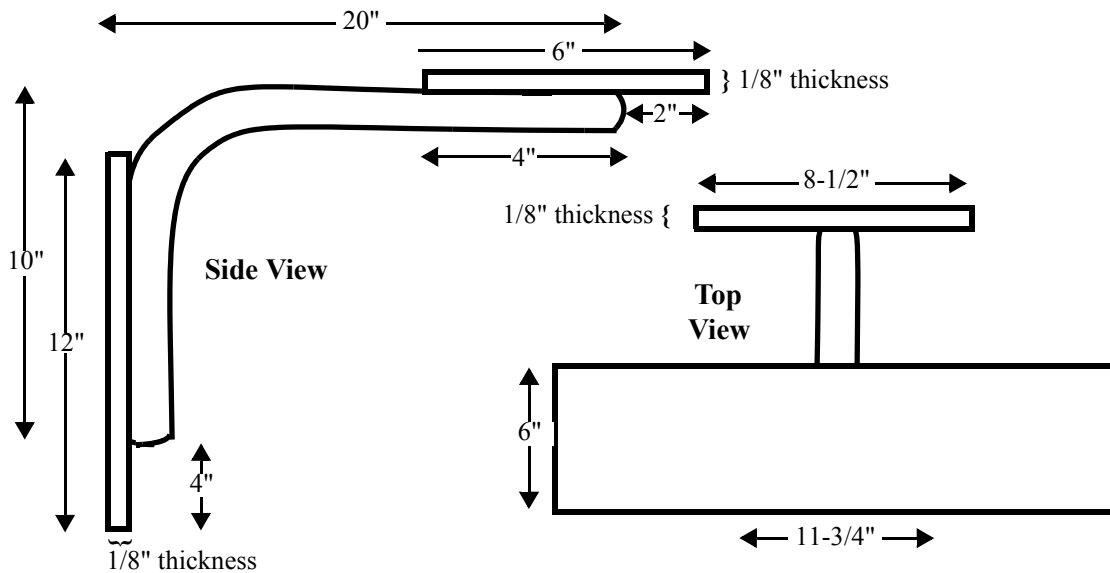

## MOUNTING DIAGRAMS

This section contains a diagram of where the mounting holes are located on the bottom of the CR1120/CR1122 and CR2000/CR2002 Copy Readers. These mounting holes allow the reader to be bolted to a mounting plate.

Mounting Diagram for CR1120/CR1122

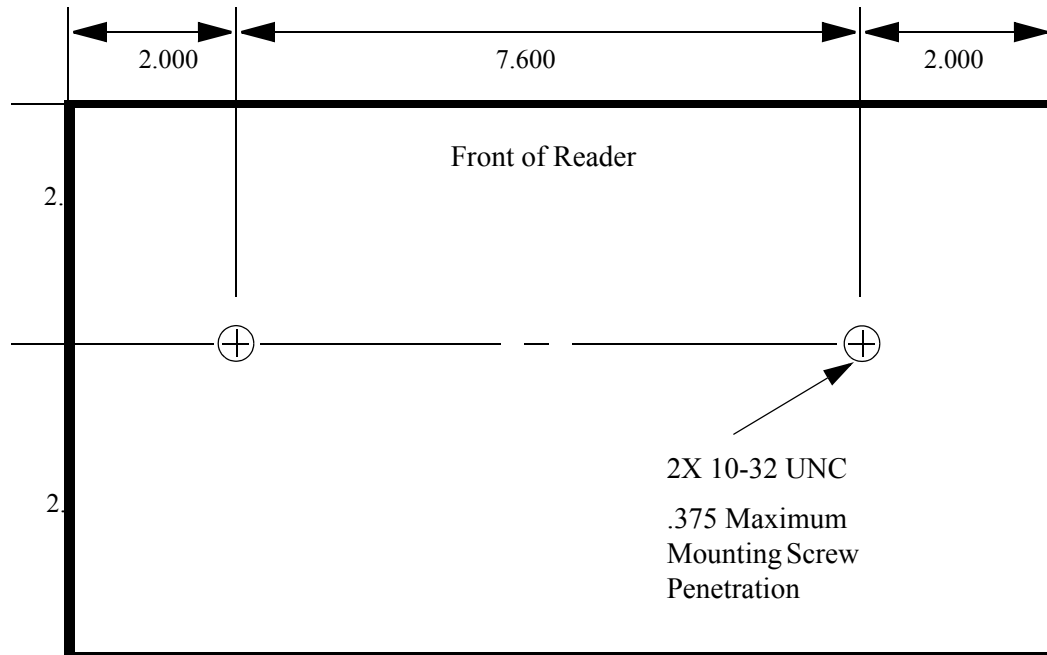



Mounting Diagram for CR2000/CR2002

